

## Wilo-Rexa FIT



**en** Installation and operating instructions



Rexa FIT  
<https://qr.wilo.com/771>

## Table of contents

<b>1 General</b> .....	<b>4</b>	<b>9 Maintenance and repair</b> .....	<b>16</b>
1.1 About these instructions .....	4	9.1 Personnel qualifications .....	16
1.2 Copyright .....	4	9.2 Operator responsibilities .....	16
1.3 Subject to change.....	4	9.3 Operating fluid .....	16
1.4 Exclusion from warranty and liability.....	4	9.4 Maintenance intervals.....	16
		9.5 Maintenance measures.....	16
<b>2 Safety</b> .....	<b>4</b>	<b>10 Faults, causes and remedies</b> .....	<b>18</b>
2.1 Identification of safety instructions .....	4	<b>11 Spare parts</b> .....	<b>19</b>
2.2 Personnel qualifications.....	4	<b>12 Disposal</b> .....	<b>19</b>
2.3 Personal protective equipment .....	5	12.1 Oils and lubricants .....	19
2.4 Electrical work .....	5	12.2 Protective clothing.....	19
2.5 Monitoring devices .....	5	12.3 Information on the collection of used electrical and elec- tronic products.....	19
2.6 Fluids hazardous to health .....	5		
2.7 Transport.....	5		
2.8 Use of lifting equipment.....	5		
2.9 Installing/dismantling.....	5		
2.10 During operation.....	6		
2.11 Clean and disinfect .....	6		
2.12 Maintenance tasks.....	6		
2.13 Operating fluid .....	6		
2.14 Operator responsibilities .....	6		
<b>3 Transportation and storage</b> .....	<b>6</b>		
3.1 Delivery.....	6		
3.2 Transport.....	6		
3.3 Storage .....	7		
<b>4 Application/use</b> .....	<b>7</b>		
4.1 Intended use.....	7		
4.2 Improper use.....	7		
<b>5 Product description</b> .....	<b>7</b>		
5.1 Description.....	7		
5.2 Materials.....	8		
5.3 Technical data .....	8		
5.4 Type key.....	8		
5.5 Operation in an explosive atmosphere .....	8		
5.6 Scope of delivery.....	9		
5.7 Accessories .....	9		
<b>6 Installation and electrical connection</b> .....	<b>9</b>		
6.1 Personnel qualifications.....	9		
6.2 Installation types .....	9		
6.3 Operator responsibilities .....	9		
6.4 Installation .....	9		
6.5 Electrical connection.....	11		
<b>7 Commissioning</b> .....	<b>13</b>		
7.1 Personnel qualifications.....	13		
7.2 Operator responsibilities .....	13		
7.3 Direction of rotation check for three-phase AC motor .....	13		
7.4 Operation in an explosive atmosphere .....	13		
7.5 Before switching on.....	13		
7.6 Switching on and off .....	14		
7.7 During operation.....	14		
<b>8 Shut-down/dismantling</b> .....	<b>15</b>		
8.1 Personnel qualifications.....	15		
8.2 Operator responsibilities .....	15		
8.3 Shut-down.....	15		
8.4 Removal.....	15		

## 1 General

### 1.1 About these instructions

These instructions form part of the product. Compliance with the instructions is essential for correct handling and use:

- Read the instructions carefully before all activities.
- Keep the instructions in an accessible place at all times.
- Observe all product specifications.
- Observe the markings on the product.

The language of the original operating instructions is German. All other languages of these instructions are translations of the original operating instructions.

### 1.2 Copyright

WILO SE © 2025

The reproduction, distribution and utilisation of this document in addition to communication of its contents to others without express consent is prohibited. Offenders will be held liable for payment of damages. All rights reserved.

### 1.3 Subject to change

Wilo shall reserve the right to change the listed data without notice and shall not be liable for technical inaccuracies and/or omissions. The illustrations used may differ from the original and are intended as an exemplary representation of the product.

### 1.4 Exclusion from warranty and liability

Wilo shall specifically not assume any warranty or liability in the following cases:

- Inadequate configuration due to inadequate or incorrect instructions by the operator or the client
- Non-compliance with these instructions
- Improper use
- Incorrect storage or transport
- Incorrect installation or dismantling
- Insufficient maintenance
- Unauthorised repairs
- Inadequate construction site
- Chemical, electrical or electrochemical influences
- Wear

## 2 Safety

This section contains basic information about the individual stages in the life cycle of the pump. Failure to observe this information leads to:

- Danger to persons
- Danger to the environment
- Property damage
- Loss of claims for damages

### 2.1 Identification of safety instructions

These installation and operating instructions set out safety instructions for preventing personal injury and damage to property. These safety instructions are shown differently:

- Safety instructions relating to personal injury start with a signal word, are **preceded by a corresponding symbol** and are shaded in grey.



#### **DANGER**

#### **Type and source of the danger!**

Consequences of the danger and instructions for avoidance.

- Safety instructions relating to property damage start with a signal word and are displayed **without** a symbol.

## **CAUTION**

### **Type and source of the danger!**

Consequences or information.

### Signal words

- **DANGER!**  
Failure to observe the safety instructions will result in serious injuries or death!
- **WARNING!**  
Failure to follow the instructions can lead to (serious) injuries!
- **CAUTION!**  
Failure to follow the instructions can lead to property damage and a possible total loss.
- **NOTICE!**  
Useful information on handling the product

### Markups

- ✓ Prerequisite
- 1. Work step/list
  - ⇒ Notice/instructions
  - ▶ Result

### Identifying cross references

The name of the section or table is in inverted commas [“ ”]. The page number follows in square brackets [ ] .

### Symbols

These instructions use the following symbols:



Danger caused by electric voltage



Danger of bacterial infection



Danger caused by explosive atmosphere



Danger of explosion



Warning of hand injuries (being crushed, cut)



Warning of hot surfaces



General warning symbol



Useful information

### 2.2 Personnel qualifications

- Personnel have been instructed on locally applicable regulations governing accident prevention.
- Personnel have read and understood the installation and operating instructions.
- Electrical work: qualified electrician  
Person with appropriate technical training, knowledge and experience who can identify and prevent electrical hazards.
- Installation/dismantling work: trained sewage technology professional  
Fixation and pipework in wet well and dry well installation, lifting equipment, basic knowledge of wastewater facilities
- Maintenance work: trained sewage technology professional  
Application/disposal of operating fluids used, basic engineering knowledge (installation/dismantling)

- Lifting work: trained specialist for the operation of lifting devices  
Lifting equipment, lifting gear, attachment points

### Children and persons with limited abilities

- Persons under the age of 16: Use of this product is prohibited.
- Persons under the age of 18: Supervise them during use of the product (supervisor)!
- Persons with limited physical, sensory or mental capacities: Use of this product is prohibited!

### 2.3 Personal protective equipment

The protective equipment specified is the minimum requirement. Observe the requirements of the work regulations.

#### Protective equipment: Transport, installation, removal and maintenance

- Safety shoes: Protection class S1 (uvex 1 sport S1)
- Protective gloves (EN 388): 4X42C (uvex C500 wet)
- Safety helmet (EN 397): Conforms to standards, protection against lateral deformation (uvex pheos)  
(If lifting equipment is used)

#### Protective equipment: Cleaning work

- Protective gloves (EN ISO 374-1): 4X42C + Type A (uvex protector chemical NK2725B)
- Safety goggles (EN 166): (uvex skyguard NT)
  - Labelling frame: W 166 34 F CE
  - Labelling disc: 0-0.0\* W1 FKN CE  
\* Protection level according to EN 170 not relevant for this work.
- Breathing protection mask (EN 149): Half mask 3M series 6000 with filter 6055 A2

#### Article recommendations

The branded products in the parentheses constitute non-binding suggestions. Similar products from other brands can also be used. Adherence to the standards mentioned is required.

WILO SE does not assume any liability for the adherence of the aforementioned products to the corresponding standards.

### 2.4 Electrical work

- Electrical work must be carried out by a qualified electrician.
- Disconnect device from the mains and secure it against being switched on again without authorisation.
- Observe applicable local regulations when connecting to the mains power supply.
- Comply with the requirements of the local energy supply company.
- Train personnel on how to make electrical connections.
- Train personnel on the options for switching off the device.
- Observe the technical information in these installation and operating instructions as well as on the rating plate.
- Earth the device.
- Observe provisions for connection to the electrical switching system.
- Comply with the specifications on electro-magnetic compatibility when using electronic start-up controllers (e.g. soft starter or frequency converter). If required, take special measures into account (e.g. shielded cables, filters, etc.).
- Replace defective connection cables. Contact customer service.

### 2.5 Monitoring devices

The following monitoring devices must be provided on-site:

#### Circuit breaker

- Design the power and switching characteristics of the circuit breakers according to the rated current of the connected product.
- Observe local regulations.

### Motor protection switch

- Product without plug: install a motor protection switch!  
The minimum requirement is a thermal relay/motor protection switch with temperature compensation, differential trip and re-activation lock according to local regulations.
- Instable mains supply systems: if necessary, install further protective devices on-site (e.g. overvoltage, undervoltage or phase failure relays, etc.).

### Residual-current device (RCD)

- Install a residual-current device (RCD) in accordance with the regulations of the local energy supply company.
- If people can come into contact with the device and conductive fluids, install a residual-current device (RCD).

### 2.6 Fluids hazardous to health

Hazardous germs form in sewage or in stagnant water. There is a danger of bacterial infections!

- Wear protective equipment!
- Clean and disinfect the product thoroughly after removal!
- Inform all persons about the pumped fluid and the danger it poses!

### 2.7 Transport

- Locally applicable laws and regulations on work safety and accident prevention must be complied with.
- Always carry the product by the handle!

### 2.8 Use of lifting equipment

If lifting equipment (lifting device, crane, chain hoist ...) is used, observe the following points:

- Wear a safety helmet according to EN 397!
- Comply with local regulations on the use of lifting equipment.
- The technically correct use of the lifting equipment is the operator's responsibility!
- **Lifting gear**
  - Use legally specified and approved lifting gear.
  - Select lifting gear based on the attachment point.
  - Attach lifting gear to the attachment point according to local regulations.
- **Lifting equipment**
  - Check its functions properly before use!
  - Sufficient bearing capacity.
  - Ensure stability during use.
- **Lifting operation**
  - Do not jam the product when lifting and lowering it.
  - Do not exceed the max. permissible bearing capacity!
  - If necessary (e.g. blocked view), assign a second person to coordinate.
  - No one should stand under suspended loads!
  - Do not move loads over workplaces where persons are present!

### 2.9 Installing/dismantling

- Locally applicable laws and regulations on work safety and accident prevention must be complied with.
- Disconnect device from the mains and secure it against being switched on again without authorisation.
- All rotating parts must stop.
- Ensure enclosed spaces have sufficient ventilation.
- When working in enclosed spaces, a second person must be present for safety reasons.
- Toxic or asphyxiating gases may build up in enclosed spaces or buildings. Observe protective measures in accordance with work regulations, e.g. carry a gas detector with you.
- Clean the device thoroughly.
- If the product has been used in fluids that are hazardous to health, disinfect the product!

### 2.10 During operation

- Demarcate and cordon off the working area.
- No persons are allowed in the working area during operation.
- Depending on the process, the product is activated and deactivated using separate controls. The product may automatically be activated following power cuts.
- If the motor emerges, the motor housing can heat up to above 40 °C (104 °F).
- Superior must be informed immediately of any faults or irregularities.
- The product must be switched off immediately if faults occur.
- Never reach into the suction port. The rotating parts can crush and sever limbs.
- Open all gate valves in the inlet and pressure pipe.
- Ensure minimum water submersion by using dry-running protection.
- Sound-pressure level depends on several factors (installation, duty point, etc.). Measure the current noise level under operating conditions. Wear hearing protection at noise levels of 85 dB(A) and over. Demarcate the working area!

### 2.11 Clean and disinfect

- If a disinfectant is used, wear protective equipment according to the manufacturer's instructions!
- Inform all persons about the disinfectant and how to use it correctly!

### 2.12 Maintenance tasks

- Disconnect device from the mains and secure it against being switched on again without authorisation.
- Clean the device thoroughly.
- If the product has been used in fluids that are hazardous to health, disinfect the product!
- Carry out maintenance work in a clean, dry and well-lit place.
- Only carry out maintenance tasks described in these installation and operating instructions.
- Only original parts of the manufacturer may be used. The use of any non-original parts releases the manufacturer from any liability.
- Collect any leakage of fluid and operating fluid immediately and dispose of it according to the locally applicable guidelines.

### 2.13 Operating fluid

The following white oils are used:

- ExxonMobile: Marcol 52
- ExxonMobile: Marcol 82

#### General remarks

- Absorb leakages immediately.
- If major leakages occur, contact customer service.
- If the seal is defective, the oil enters the pumped fluid.

#### First aid measures

- **Skin contact**
  - Rinse skin areas thoroughly with soap and water.
  - If skin irritation occurs, consult a doctor.
  - In case of contact with open skin, consult a doctor!
- **Eye contact**
  - Remove the contact lenses.
  - Rinse eye thoroughly with water.
  - If eye irritation occurs, consult a doctor.
- **Inhalation**
  - Remove from the contact area!
  - Create air exchange!
  - If the respiratory tract becomes irritated or there is dizziness or nausea, consult a doctor immediately!
- **Ingestion**
  - Consult a doctor **immediately!**
  - **Do not** induce vomiting!

### 2.14 Operator responsibilities

- Provide installation and operating instructions in a language which the personnel can understand.
- Make sure that the personnel have received the required training for the specified work.
- Provide protective equipment. Ensure that the protective equipment is worn by personnel.
- Ensure that safety and information signs mounted on the device are always legible.
- Train the personnel on how the system operates.
- Fit dangerous components within the system with an on-site guard.
- Demarcate and cordon off the working area.
- Measure the noise level. At noise levels of 85 dB(A) and over, wear hearing protection. Demarcate the working area!

## 3 Transportation and storage

### 3.1 Delivery

- After receiving the shipment, check it immediately for defects (damage, completeness).
- Defects must be noted on the freight documentation.
- Defects must be notified to the transport company or the manufacturer on the day of receipt of shipment.
- Subsequently notified defects can no longer be asserted.

### 3.2 Transport

#### CAUTION

#### Property damage due to wet packaging!

Wet packaging may tear. If unprotected, the product may fall on the ground and be irreparably damaged.

- Carefully lift wet packaging and replace it immediately.

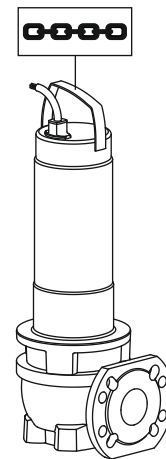

Fig. 1: Slinging point

- Wear protective equipment! Observe the work regulations.
  - Protective gloves: 4X42C (uvex C500 wet)
  - Safety shoes: Protection class S1 (uvex 1 sport S1)
- Carry the pump by the handle!
- Protect the connection cable against water ingress. Do not immerse attached plugs in the pumped fluid.
- Only remove the outer packaging at the place of utilisation to ensure that the pump is not damaged during transport.
- Use tear-proof plastic sacks of sufficient size to package the used pump for transport in a leak-proof manner.

### 3.3 Storage



#### DANGER

**Danger due to fluids which are hazardous to health!**

Danger of bacterial infection!

- Disinfect the pump after removal!
- Observe the specifications of the work regulations!



#### WARNING

**Risk of injury from sharp edges!**

Sharp edges can form on the impeller and suction port. There is a danger of cuts and similar injuries!

- Wear protective gloves!

#### CAUTION

**Total loss due to moisture ingress!**

Moisture ingress in the connection cable damages the connection cable and may cause the pump to be irreparably damaged.

- Never immerse open ends of the connection cables in fluid. Seal them in a watertight manner during storage (avoid condensation).

- Place the pump upright (vertical) on a firm bearing surface.
- Secure the pump against falling over and slipping!
- Store the pump for a maximum of one year. Consult the customer service before storing the device for more than one year.
- Storage conditions:
  - Maximum: -15 to +60 °C (5 to 140 °F), max. humidity: 90 %, non-condensing.
  - Recommended: 5 to 25 °C (41 to 77 °F), relative humidity: 40 to 50 %.
  - Protect the pump from direct exposure to sunlight. Extreme heat can cause damage!
- Do not store the pump in rooms where welding work is carried out. The resulting gases or radiation can corrode the elastomer parts and coatings.
- Seal the suction and pressure connection tightly.
- Protect the connection cable against kinking and damage. Maintain a constant bend radius!
- Impellers must be turned by 180° at regular intervals (3 – 6 months). This prevents the bearings from jamming and renews the lubrication film on the mechanical seal. **NOTICE! Wear protective gloves!**

## 4 Application/use

### 4.1 Intended use

For pumping in commercial areas of:

- Sewage containing faeces
- Wastewater (with small amounts of sand and gravel)

#### Sewage pumping according to 12050

The pumps meet the requirements of EN 12050-1.

### 4.2 Improper use



#### DANGER

**Explosion due to pumping of explosive fluids!**

Pumping highly inflammable and explosive fluids (e.g. petrol, paraffin, etc.) in their pure form poses a risk of fatal injury due to explosion!

- The pumps are not designed for these fluids.
- The pumping of highly inflammable and explosive fluids is prohibited.

The submersible pumps must **not be used** for pumping:

- Drinking water
- Fluids containing hard components (such as stones, wood, metal, etc.)
- Fluids containing high quantities of abrasive contents (e.g. sand, gravel).

Intended use also includes compliance with this manual. Any other use is regarded as non-compliant with intended use.

## 5 Product description

### 5.1 Description

Submersible pump for stationary and portable wet well installation in intermittent operation.

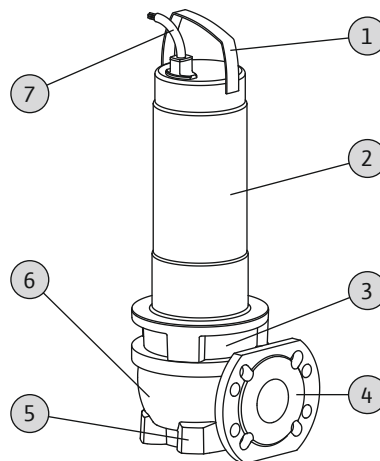

Fig. 2: Overview

1	Handle/sliding point
2	Motor
3	Seal housing
4	Discharge port
5	Suction port
6	Hydraulics housing
7	Connection cable

#### Rexa FIT-V ... /M ... /P

Submersible pump with vortex impeller and horizontal discharge port with flange connection. Hydraulics housing and impeller made of grey cast iron. Surface-cooled 1~ motor with integrated operating capacitor and self-switching thermal motor monitoring. Oil-filled sealing chamber with two mechanical seals. Stainless steel motor housing. Detachable connection cable with fitted plug (CEE7/7). The pump may be used in Zone 2 hazardous areas.

### Rexa FIT-V ... /M ... /A

Submersible pump with vortex impeller and horizontal discharge port with flange connection. Hydraulics housing and impeller made of grey cast iron. Surface-cooled 1~ motor with integrated operating capacitor and self-switching thermal motor monitoring. Oil-filled sealing chamber with two mechanical seals. Stainless steel motor housing. Detachable connection cable with float switch and fitted plug (CEE7/7). The pump must **not** be used in hazardous areas.

### Rexa FIT-V ... /T ... /A

Submersible pump with vortex impeller and horizontal discharge port with flange connection. Hydraulics housing and impeller made of grey cast iron. Surface-cooled 3~ motor with thermal motor monitoring. Oil-filled sealing chamber with two rotating ring seals. Stainless steel motor housing. Detachable connection cable with CEE plug (3+N+PE, 6h). Float switch and thermal motor monitoring connected to the CEE plug. The pump must **not** be used in hazardous areas.

### Rexa FIT-V ... /T ... /O

Submersible pump with vortex impeller and horizontal discharge port with flange connection. Hydraulics housing and impeller made of grey cast iron. Surface-cooled 3~ motor with thermal motor monitoring. Oil-filled sealing chamber with two mechanical seals. Stainless steel motor housing. Detachable connection cable with bare cable ends. The pump may be used in Zone 2 hazardous areas.

## 5.2 Materials

- Hydraulics housing: EN-GJL-250 (ASTM A48 Class 35/40B)
- Impeller: EN-GJL-250 (ASTM A48 Class 35/40B)
- Motor housing: 1.4301 (AISI 304)
- Shaft: 1.4021 (AISI 420)
- Seal on the motor side: C/MgSiO<sub>4</sub>
- Seal on the fluid side: SiC/SiC
- Seal, static: NBR (nitrile)

## 5.3 Technical data

General	
Date of manufacture* [MFY]	See rating plate
Mains connection [U/f]	See rating plate
Power consumption [P <sub>1</sub> ]	See rating plate
Rated power [P <sub>2</sub> ]	See rating plate
Max. delivery head [H]	See rating plate
Max. volume flow [Q]	See rating plate
Activation type [AT]	Direct
Fluid temperature [t]	3 ... 40 °C (37 ... 104 °F)
Fluid temperature, short-term	60 °C (140 °F) for 3 min
IP rating	IP68
Insulation class [Cl.]	F
Speed [n]	See rating plate
Max. switching frequency	60/h
Immersion depth, max.	7 m (23 ft)
Cable length	10 m (33 ft)
Operating modes	
Immersed	S1
Non-immersed	S2-15 min; S3 10%
Discharge port	
FIT-V05 ...	DN 50, PN 10
FIT-V06 ...	DN 65/80, PN 10

FIT-V08 ...	DN 80/100, PN 10
FIT-V10 ...	DN 100, PN 0
Suction port	
FIT-V05 ...	DN 50, PN 10
FIT-V06 ...	DN 65, PN 10
FIT-V08 ...	DN 80, PN 10
FIT-V10 ...	DN 100, PN 10
Extended use	
Explosion protection	IECEX, ATEX (depending on the type)
Operation on frequency converter	-

\*The date of manufacture is stated in accordance with ISO 8601: JJJJWww

- JJJJ = year
- W = abbreviation for week
- ww = calendar week

## 5.4 Type key

Ex-ample:	<b>Wilo-Rexa FIT-V06-212A/21T011-540/A</b>
<b>Rexa</b>	Submersible sewage pump
<b>FIT</b>	Series
<b>V</b>	Impeller shape: Vortex impeller
<b>06</b>	Nominal diameter of discharge port, e.g. DN 65
<b>212</b>	Hydraulics type
<b>A</b>	Hydraulics material version: Standard version
<b>2</b>	Number of poles
<b>1</b>	IE-efficiency class (derived from IEC 60034-30)
<b>T</b>	Mains connection version: <ul style="list-style-type: none"> <li>• M = alternating current (1~)</li> <li>• T = three-phase current (3~)</li> </ul>
<b>011</b>	Value/10 = rated power P <sub>2</sub> in kW
-	Not Ex-rated
<b>5</b>	Mains frequency: 5 = 50 Hz/6 = 60 Hz
<b>40</b>	Rated voltage code
<b>A</b>	Additional electrical equipment: <ul style="list-style-type: none"> <li>• P = with plug</li> <li>• A = with plug and float switch</li> <li>• O = with bare cable end</li> </ul>

## 5.5 Operation in an explosive atmosphere

	ATEX, zone 2	ATEX, zone 1	IECEX, zone 2	IECEX, zone 1
Rexa FIT-V ... /P	•	-	•	-
Rexa FIT-V ... /A	-	-	-	-
Rexa FIT-V ... /O	•	-	•	-

### IECEX certification

The pumps are suitable for operation in hazardous areas:

- Device group: II

- Category: 3, zone 2

**These pumps must not be used in zone 1 and zone 0!**

#### Self-declaration according to ATEX

The pumps are suitable for operation in hazardous areas:

- Device group: II
- Category: 3, zone 2

**These pumps must not be used in zone 1 and zone 0!**

**CAUTION! Property damage! Protect cable inlet against mechanical hazards >4 J (see EN IEC 60079-0, table 15).**

#### 5.6 Scope of delivery

- Pump
- Installation and operating instructions

#### 5.7 Accessories

- Connection cable with fixed cable lengths up to max. 30 m (98 ft).
- External pencil electrode for monitoring the sealing chamber
- Suspension unit for wet well installation
- Pump support foot for portable installation
- Level control devices
- Fixation sets with anchor bolts
- Fixation accessories and chains
- Switchgear, relays and plugs

## 6 Installation and electrical connection

### 6.1 Personnel qualifications

- Electrical work: qualified electrician  
Person with appropriate technical training, knowledge and experience who can identify and prevent electrical hazards.
- Installation/dismantling work: trained sewage technology professional  
Fixation and pipework in wet well and dry well installation, lifting equipment, basic knowledge of wastewater facilities

### 6.2 Installation types

- Vertical stationary wet well installation with suspension unit
- Vertical portable wet well installation with pump support foot

### 6.3 Operator responsibilities

- Observe locally applicable accident prevention and safety regulations.
- Observe all regulations for working with heavy loads and under suspended loads.
- Provide protective equipment. Ensure that the protective equipment is worn by personnel.
- Observe local sewage technology regulations for the operation of sewage systems.
- Avoid pressure surges!  
Pressure surges can occur in long pressure pipes with steep terrain. These pressure surges can lead to the destruction of the pump!
- Ensure the cooling time of the motor depending on the operating conditions and the size of the pump chamber.
- Structural components and foundations must be of sufficient stability in order to allow the device to be fixed in a secure and functional manner. The operator is responsible for the provision and suitability of the structural component/foundation!
- Check that the available consulting documents (installation plans, installation location, inflow conditions) are complete and accurate.

## 6.4 Installation



### DANGER

#### Danger of death due to dangerous lone working practices!

Work in chambers and narrow rooms as well as work involving risk of falling are dangerous work. Such work may not be carried out autonomously!

- Only carry out work with another person!

- Wear protective equipment! Observe the work regulations.
  - Protective gloves: 4X42C (uvex C500 wet)
  - Safety shoes: Protection class S1 (uvex 1 sport S1)
  - Safety helmet: EN 397 Conforms to standards, protection against lateral deformation (uvex pheos)  
(When using lifting equipment)
- Prepare the installation site:
  - Clean, free of coarse solids
  - Dry
  - Frost-free
  - Disinfected
- Toxic or asphyxiating gases may build up during work:
  - Observe protective measures in accordance with work regulations (gas measurement, carry a gas detector with you).
  - Ensure adequate ventilation.
  - If toxic or asphyxiating gases accumulate, leave the workplace immediately!
- Always carry the pump by the handle!
- Install lifting equipment: even surface, clean, firm base. Warehouse and installation location must be easily accessible.
- Attach chain or wire rope to handle/attachment point with a shackle. Only use lifting gear that has been technically approved.
- All connection cables must be laid properly. The connection cables must not pose any risk (i.e. tripping, damage during operation). Check whether the cable cross-section and the cable length are sufficient for the selected installation type.
- Installation of switchgear: Observe information in the manufacturer's instructions (IP class, overflow-proof, potentially explosive atmospheres)!
- Avoid air intake into the fluid. Use baffles or deflector plates at the inlet. Install the ventilation systems!
- Do not allow the pump to run dry! Avoid air pockets. Do not go below the minimum water level. Installation of dry-running protection is recommended!

### 6.4.1 Indications for double pump operation

If several pumps are used in an operating space, minimum distances between the pumps and the wall must be complied with. Here there is a difference in the distances depending on the type of system: Alternating operation or parallel operation.

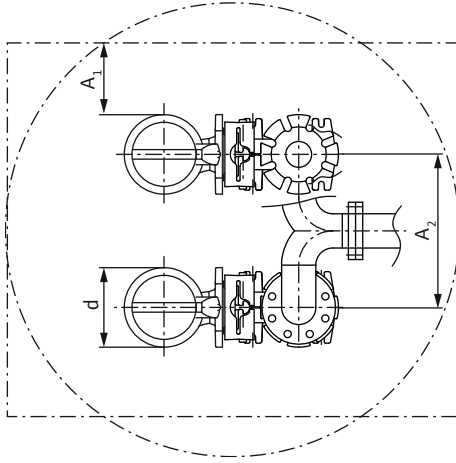

Fig. 3: Minimum distances

d	Diameter hydraulics housing
A <sub>1</sub>	Minimum distance from the wall: - alternating operation: min. 0.3 × d - parallel operation: min. 1 × d
A <sub>2</sub>	Distance to pressure pipes - alternating operation: min. 1.5 × d - parallel operation: min. 2 × d

#### 6.4.2 Maintenance tasks

After a storage period of more than 12 months, carry out the following maintenance tasks before installation:

- Rotate the impeller. See section “Rotate impeller [► 17]”.
- Check the oil in the sealing chamber and replace it if necessary. See section “Oil change in sealing chamber [► 17]”.

#### 6.4.3 Stationary wet well installation

The pump is installed in a pump chamber or basin. A suspension unit is installed to connect the pump to the pressure pipe. The on-site pressure pipe is connected to the suspension unit. The pump is connected to the suspension unit via a coupling connection.

The pressure pipe must meet the following requirements:

- The connected pressure pipe is self-supporting. The pressure pipe must **not** be supported by the suspension unit!
- The pressure pipe must not be smaller than the pump’s discharge connection.
- All prescribed valves (gate valves, backflow preventers ...) are present.
- Pressure pipe laid frost-proof.
- Ventilation systems (e.g. air vent valves) installed. Air pockets in the pump and in the pressure pipe can lead to delivery problems.

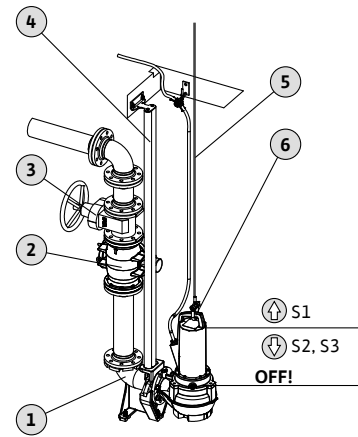

Fig. 4: Stationary wet installation

1	Suspension unit
2	Non-return valve
3	Stop valve
4	Guide pipes (provided by the customer)
5	Lifting accessories
6	Slinging point for lifting accessories
⬆	Fill level above: Immersed operating mode
⬇	Fill level below: Non-immersed operating mode
OFF	Min. water level. Switch off the pump.

- ✓ Place of use prepared.
  - ✓ Suspension unit installed.
  - ✓ Coupling connection mounted on the pump.
1. Use a shackle to attach the lifting equipment to the attachment point on the pump.
  2. Lift the pump and swing it over the opening of the pump chamber.
  3. Slowly drain the pump and thread the guide pipes into the coupling connection.
  4. Lower the pump until it sets on the suspension unit and is connected automatically. **CAUTION! Hold the connection cables slightly taut when lowering the pump!**
  5. Loosen the lifting gear from the lifting equipment and secure it against falling at the pump chamber outlet.
  6. Correctly route the connection cables and lead them out of the pump chamber. **CAUTION! Do not damage the connection cables!**
    - No chafing or kinking.
    - Do not immerse the cable end in the fluid.
    - Observe the bending radii.
- Pump installed, make the electrical connection.

#### 6.4.4 Portable wet well installation

Attach the pump support foot (available separately as an accessory) to the pump. The pump support foot allows the pump to be positioned anywhere at the place of use. A pressure hose is connected on the discharge side.

- Use a hard surface or underlay at the place of use to prevent sinking on a soft bearing surface.
- If the pump is used at the same location for a longer period of time, bolt the pump support foot to the floor. This reduces vibrations and enables quiet operation.

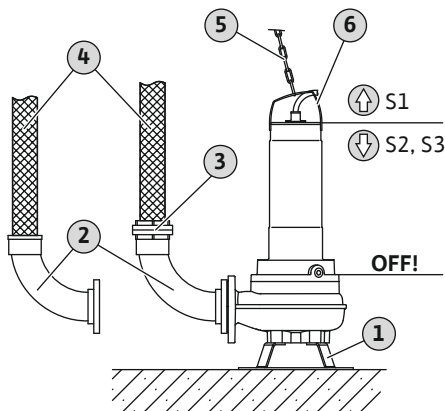

Fig. 5: Portable wet installation

1	Pump support foot
2	Pipe elbow with hose connection or Storz fixed coupling
3	Storz hose coupling
4	Pressure hose
5	Lifting accessories
6	Slinging point
↑	Fill level above: Immersed operating mode
↓	Fill level below: Non-immersed operating mode
OFF	Min. water level. Switch off the pump.

- ✓ Place of use prepared.
  - ✓ Pump support foot mounted.
  - ✓ Discharge connection prepared: Hose connection or Storz coupling fitted.
  - ✓ Soft bearing surface: solid surface available.
1. Use a shackle to attach the lifting equipment to the attachment point on the pump.
  2. Lift and align the pump at the installation location.
  3. Place the pump on a firm bearing surface. Avoid sinking!
  4. Secure the pump against moving and falling over: Bolt the pump support foot to the floor.
  5. Lay the pressure hose and fasten it properly at the appropriate place (e.g. drainage).
  6. Correctly route the connection cables. **CAUTION! Do not damage the connection cables!**
    - No chafing or kinking.
    - Do not immerse the cable end in the fluid.
    - Observe the bending radii.
- ▶ Pump installed, make the electrical connection.

#### 6.4.5 Level control

The "A" version is equipped with a float switch. The pump is switched on and off depending on the fill level. The switching level is determined by the cable length of the float switch.

Observe the following points during installation:

- Float switch must be able to move freely!
  - The minimum permissible water level is **not fallen short of!**
  - The maximum switching frequency is **not exceeded!**
- In order to achieve larger switching differences in case of strongly fluctuating fill levels, provide a level control with two measuring points.

#### 6.4.6 Dry-running protection

Dry-running protection prevents the pump from being operated without fluid and air from entering the hydraulics. For this purpose,

the minimum permissible fill level is monitored using an external control. When the minimum fill level is reached, the pump is switched off. Furthermore, depending on the control, a visual and acoustic alarm is triggered.

The dry-running protection can be integrated into existing controls as an additional measuring point. Alternatively, the dry-running protection can also work as a stand-alone shut-off device. Depending on the system security, the pump can be restarted automatically or manually.

Installation of dry-running protection is recommended for optimum operational reliability.

## 6.5 Electrical connection



### DANGER

#### Danger of death due to electrical current!

Improper conduct when carrying out electrical work can lead to death due to electric shock!

- Before all electrical work, disconnect the product from the mains and secure it against being switched on again without authorisation.
- Electrical work must be carried out by a qualified electrician!
- Observe local regulations!



### DANGER

#### Risk of explosion due to incorrect electrical connection!

If the pump is used in hazardous areas, there is danger of death from explosion if the electrical connection is faulty! Observe the following points when using the pump in hazardous areas:

- Establish the electrical connection outside the hazardous area.
- If the connection must be established within hazardous areas, the electrical connection must be carried out in an Ex-rated housing (ignition protection class according to EN 60079-0).
- Connect equipotential bonding to the handle (drilled hole) with screw, nut and tooth lock washer. The equipotential bonding cable must comply with local regulations.

- Mains connection corresponds to the information on the rating plate.
- Power supply on mains side with clockwise rotating field for three-phase AC motors (3~ motor).
- Route the connection cables according to the local regulations and connect them according to the wire assignment.
- Connect **all** of the monitoring devices and check their function.
- Secure the earthing in accordance with the local regulations.

#### 6.5.1 Fuse on mains side

##### Circuit breaker

- Design the power and switching characteristics of the circuit breakers according to the rated current of the connected product.
- Observe local regulations.

### Motor protection switch

- Product without plug: install a motor protection switch!  
The minimum requirement is a thermal relay/motor protection switch with temperature compensation, differential trip and re-activation lock according to local regulations.
- Instable mains supply systems: if necessary, install further protective devices on-site (e.g. overvoltage, undervoltage or phase failure relays, etc.).

### Residual-current device (RCD)

- Install a residual-current device (RCD) in accordance with the regulations of the local energy supply company.
- If people can come into contact with the device and conductive fluids, install a residual-current device (RCD).

### 6.5.2 Maintenance tasks

- Check the insulation resistance of the motor winding.
- Check the resistance of the temperature sensors.

#### 6.5.2.1 Checking the insulation resistance of the motor winding

- ✓ Insulation tester 1000 V
  - ✓ Motors with **built-in capacitor**: Short-circuited windings!
1. Check the insulation resistance.
    - ⇒ Measured value at initial commissioning:  $\geq 20 \text{ M}\Omega$ .
    - ⇒ Measured value at interval measurement:  $\geq 2 \text{ M}\Omega$ .
    - ▶ Insulation resistance checked. If the measured values deviate from the specifications, consult the customer service.

#### 6.5.2.2 Test the resistor of the temperature sensor

- ✓ Ohmmeter available.
1. Measure the resistance.
    - ⇒ Measured value **Bimetallic strip**: 0 ohms (passage).
    - ▶ Resistance checked. If the measured value deviates from the specification, consult the customer service.

### 6.5.3 Connection of the single-phase AC motor (1~ motor)

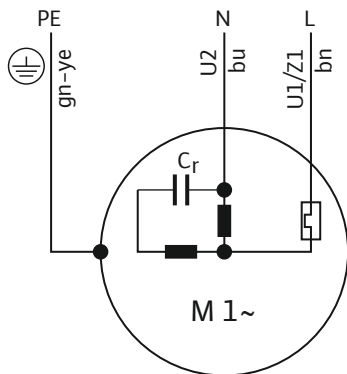

Fig. 6: Connection diagram 1~ motor

Wire colour	Terminal
Brown (bn)	L
Blue (bu)	N
Green/yellow (gn-ye)	Earth

The pump is equipped with a plug (CEE 7/7). Connection to the mains is established by inserting the plug into the socket (type E or type F). The plug is not watertight.

Bimetallic sensors are installed in the motor for thermal motor monitoring. The motor monitoring is self-switching. Separate connection is not possible.

If the pump is directly connected to the switchgear, cut off the plug. Connect the connection cable according to the connection diagram in the switchgear.

### 6.5.4 Connection of the three-phase AC motor (3~ motor)

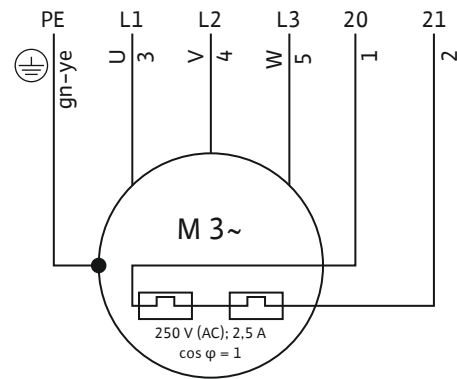

Fig. 7: Connection diagram 3~ motor

Wire number	Name	Terminal
1	20	WSK
2	21	WSK
3	U	L1
4	V	L2
5	W	L3
Green/yellow (gn-ye)	Earth	PE

#### Pump with plug

The pump has a CEE motor protection plug (3P+N+PE, 6 h). The connection to the mains is established by inserting the plug into the socket. The plug is not watertight.

The thermal motor monitoring (bimetallic sensor) is connected in the motor protection plug. When the max. winding temperature is reached, the pump is deactivated. Reactivation must be done manually. Separate connection of the motor monitoring is not necessary.

#### Pump with bare cable end

- Connection cable with bare cable ends.
- Connection in the switchgear according to the connection diagram.
- Mains connection with clockwise-rotating field
- Thermal motor monitoring:
  - Sensor: Bimetallic sensor
  - Number of temperature circuits: 1, Temperature limiter
  - Connection values: max. 250 V(AC), 2.5 A,  $\cos \phi = 1$
  - Threshold value: is set by sensor.
  - Triggering status: If the threshold value is reached, switch off the pump!

### 6.5.5 Optional equipment

Information on electrical accessory connection or possible special configurations. Please refer to the order confirmation or configuration overview for details on the special configuration.

6.5.5.1 Connection external pencil electrode

**CAUTION**

**Trigger status for sealing chamber monitoring**

The pencil electrode detects water ingress into the sealing chamber. The threshold value is reached when a certain amount of water is present in the oil. An alarm is triggered or the pump is switched off via the evaluation relay:

- The pump may be a total loss if only an alarm occurs.
- Recommendation: Always switch off the pump!

The connection must be made via an evaluation relay (e.g. "NIV 101/A"):

- Sensor: Electrode
- Connection values: max. 250 V~, 2.5 A, cos phi = 1
- Threshold: 30 kOhm
- Triggering status: If the threshold value is reached, trigger the alarm or switch off the pump!

6.5.6 Motor protection adjustment

6.5.6.1 Direct activation

- **Full load**  
Set the motor protection to the rated current according to the rating plate.
- **Partial load operation**  
Set the motor protection to 5 % above the current measured at the duty point.

6.5.6.2 Soft starter

- **Full load**  
Set the motor protection to the rated current according to the rating plate.
- **Partial load operation**  
Set the motor protection to 5 % above the current measured at the duty point.

Please observe the following points:

- Current consumption must always be below the rated current.
- Complete starting and stopping within 10 s.
- To avoid power dissipation, bypass the electronic starter (soft start) once normal operation is reached.

6.5.7 Operation with frequency converter

Operation on the frequency converter is not permitted.

7 Commissioning



**NOTICE**

**Automatic activation after power cut**

Depending on the process, the product is activated and deactivated using separate controls. The product may automatically be activated following power cuts.

7.1 Personnel qualifications

- Operation/control: Operating personnel, instructed in the functioning of the complete system

7.2 Operator responsibilities

- Providing installation and operating instructions by the pump or at a place specially reserved for it.

- Making the installation and operating instructions available in the language of the personnel.
- Making sure that the installation and operating instructions are read and understood by all personnel.
- All safety devices and emergency cut-outs on the system-side must be active and checked to ensure that they work properly.
- The pump is suitable for use under the specified operating conditions.

7.3 Direction of rotation check for three-phase AC motor

The pump requires a clockwise rotating field at the mains connection. The pump is **not** suitable for operation with a counter-clockwise rotating field.

1. Check the rotating field at the mains connection with a rotating-field testing device.
  - ⇒ Clockwise rotating field: Direction of rotation correct.
  - ⇒ Counter-clockwise rotating field: Incorrect direction of rotation. Correct the rotating field at the mains connection (see point 2).
2. To **correct** the rotating field at the mains connection:
  - ⇒ Direct starting: exchange two phases at the mains connection.
  - ⇒ Star-delta starting: Swap the connections of two windings (e.g. U1/V1 and U2/V2).

7.4 Operation in an explosive atmosphere



**DANGER**

**Risk of explosion due to flying sparks in the hydraulics!**

There is a risk of explosion due to sparks during operation! Always immerse the hydraulics in the pumped fluid completely during operation.

- Prevent air intake into the fluid. Install deflector plate at inlet.
- Do not allow the hydraulics to emerge. Switch off the pump at the "upper edge of hydraulics" fill level.
- Install dry-running protection with a reactivation lock.

	ATEX, zone 2	ATEX, zone 1	IECEx, zone 2	IECEx, zone 1
Rexa FIT-V ... /P	•	–	•	–
Rexa FIT-V ... /A	–	–	–	–
Rexa FIT-V ... /O	•	–	•	–

Identification of Ex-rated pumps

The pump is labelled as follows on the rating plate for use in explosive atmospheres:

- "Ex" symbol of the corresponding approval
- Ex classification

7.5 Before switching on

Check the following prior to activation:

- Has the electrical connection been carried out in accordance with regulations?
- Has the connection cable been routed safely?

- Can the float switch move freely?
- Accessories attached correctly?
- Temperature of the pumped fluid observed?
- Immersion depth observed?
- Are the pressure pipe and pump sump free of deposits?
- All gate valves in the pressure pipe open?
- Are ventilation systems present in the pressure pipe?  
Air pockets in the pump and in the pressure pipe can lead to delivery problems.

### 7.6 Switching on and off

- When the pump starts, the rated current is exceeded for a short time.
- During operation, do not exceed the rated current any more.

**CAUTION! Material damage! If the pump does not start, switch off the pump immediately. Motor failure! Remove the fault first before reactivation.**

Observe the following points for transportable installation:

- Place the pump on a firm bearing surface. Avoid sinking!
- If the pump has fallen over, place it upright again before activating it.
- If the pump “moves away”, screw the pump to the ground.

#### Pump with attached float switch and plug

- Single-phase AC version (1~ motor)  
Insert the plug into the socket, the pump is ready for operation. The pump switches on and off automatically depending on the fill level.
- Three-phase AC version (3~ motor):  
Insert the plug into the socket, the pump is ready for operation. The pump is controlled via two switches on the plug:
  - HAND/AUTO: Set the operating mode.  
HAND: Switch the pump on and off manually. AUTO: Switch the pump on and off automatically depending on the fill level.
  - ON/OFF: Switch the pump on and off in operating mode “HAND”.

#### Pump with attached plug

- Single-phase AC version (1~ motor):  
Insert the plug into the socket, the pump is switched on.
- Three-phase AC version (3~ motor):  
Insert the plug into the socket, the pump is ready for operation. Switch the pump on and off with the ON/OFF switch.

#### Pumps with bare cable end

The pump is switched on and off using a separate operating point (on/off switch, switchgear) provided by the customer.

### 7.7 During operation



#### WARNING

##### Risk of injury from rotating components!

No persons are allowed to be present in the working area of the pump. There is a risk of injury!

- Demarcate and cordon off the working area.
- If there are no persons in the working area, activate the pump.
- If persons enter the working area, switch off the pump immediately.



#### WARNING

##### Risk of burns from hot surfaces!

Motor housing can become hot during operation. It may cause burns.

- Allow the pump to cool down at ambient temperature after switching it off!

#### CAUTION

##### Property damage due to dry running of the pump!

Dry running may destroy the seal and cause the pump to be irreparably damaged. Dry running of the pump is prohibited.

- When the minimum delivery level is reached, switch off the pump.



#### NOTICE

##### Pumping problems due to water level being too low

The hydraulics are self-venting. Smaller air cushions are resorbed during pumping. If the fluid is lowered too much, separation of the volume flow may occur. The minimum permissible water level must reach the upper edge of the hydraulics housing!

Please regularly check the following points:

- Inlet quantity corresponds to the pump delivery rate.
- The level control device and dry-running protection work correctly.
- Minimum water submersion ensured.
- Connection cable is not damaged.
- Pump free from deposits and encrustations.
- No air intake in the pumped fluid.
- All gate valves open.
- Quiet and low-vibration running.
- Max. switching frequency not exceeded.
- Mains connection tolerances:
  - Operating voltage: +/- 10 %
  - Frequency: +/- 2 %
  - Current consumption between the individual phases: max. 5 %
  - Voltage difference between the individual phases: max. 1 %



#### NOTICE

##### Emerge the motor during operation

- If the motor is emerged during operation, observe the “operating mode non-immersed”! See indication “OT<sub>E</sub>” on the rating plate!
- Ensure cooling of the motor for continuous duty: The motor must be completely immersed before reactivation!

**Operating mode S3 10 %:** Operating mode S3 25 % is permitted if the necessary motor cooling is ensured before reactivation! To ensure the required cooling, the motor must be completely immersed for at least 1 min!

## 8 Shut-down/dismantling

### 8.1 Personnel qualifications

- Operation/control: Operating personnel, instructed in the functioning of the complete system
- Electrical work: qualified electrician  
Person with appropriate technical training, knowledge and experience who can identify and prevent electrical hazards.
- Installation/dismantling work: trained sewage technology professional  
Fixation and pipework in wet well and dry well installation, lifting equipment, basic knowledge of wastewater facilities

### 8.2 Operator responsibilities

- Locally applicable accident prevention and safety regulations of trade associations.
- Observe regulations for working with heavy loads and under suspended loads.
- Provide the necessary protective equipment and make sure that the personnel wears it.
- Provide adequate aeration in closed rooms.
- Take immediate countermeasures if there is a build-up of toxic or suffocating gases!

### 8.3 Shut-down

The pump is deactivated, but remains installed. This ensures that the pump is always ready for operation.

- ✓ Completely immerse the pump in the fluid to protect the pump from frost and ice.
  - ✓ Minimum fluid temperature: +3 °C (+37 °F).
1. Switch off the pump.
  2. Secure the operating point against being switched on again by unauthorised persons (e.g. lock main switch).
    - ▶ The pump is decommissioned.

If the pump remains installed after decommissioning, observe the following points:

- Ensure that the aforementioned requirements are maintained for the complete period of shutdown. Remove the pump if meeting these requirements cannot be guaranteed!
- For an extended period of shutdown, carry out a function test at regular intervals:
  - Period: monthly to quarterly
  - Running time: 5 minutes
  - Only run a function test in valid operating conditions!

### 8.4 Removal



#### DANGER

#### Danger due to fluids which are hazardous to health!

Danger of bacterial infection!

- Disinfect the pump after removal!
- Observe the specifications of the work regulations!



#### DANGER

#### Danger of death due to electrical current!

Improper conduct when carrying out electrical work can lead to death due to electric shock!

- Before all electrical work, disconnect the product from the mains and secure it against being switched on again without authorisation.
- Electrical work must be carried out by a qualified electrician!
- Observe local regulations!



#### DANGER

#### Danger of death due to dangerous lone working practices!

Work in chambers and narrow rooms as well as work involving risk of falling are dangerous work. Such work may not be carried out autonomously!

- Only carry out work with another person!



#### WARNING

#### Risk of burns from hot surfaces!

Motor housing can become hot during operation. It may cause burns.

- Allow the pump to cool down at ambient temperature after switching it off!

Wear the following protective equipment while performing the work:

- Safety shoes: Protection class S1 (uvex 1 sport S1)
- Protective gloves: 4X42C (uvex C500 wet)
- Safety helmet: EN 397 Conforms to standards, protection against lateral deformation (uvex pheos)  
(When using lifting equipment)

If contact with hazardous fluid occurs during work, wear the following additional protective equipment:

- Safety goggles: uvex skyguard NT
  - Labelling frame: W 166 34 F CE
  - Labelling disc: 0-0.0\* W1 FKN CE
- Breathing protection: Half mask 3M series 6000 with filter 6055 A2

The protective equipment specified is the minimum requirement. Observe the specifications of the work regulations!

\* Protection level according to EN 170 not relevant for this work.

#### 8.4.1 Stationary wet well installation

- ✓ Pump is decommissioned.
  - ✓ Gate valves on the inlet and pressure sides are closed.
1. Disconnect the pump from the mains.
  2. Attach the lifting equipment to the attachment point.
  3. Slowly raise the pump and lift it over the guide pipes out of the operating space. **CAUTION! Do not damage the connection cable! Hold the connection cables slightly taut when lifting!**
  4. Coil up the connection cables and attach them to the motor.
    - Do not kink.
    - Do not crush.
    - Observe the bending radii.

5. Thoroughly clean the pump (see section “Cleaning and disinfecting”).

#### 8.4.2 Portable wet well installation

- ✓ Pump has been decommissioned.
1. Disconnect the pump from the mains.
  2. Coil up the connection cables and attach them to the motor.
    - Do not kink.
    - Do not crush.
    - Observe the bending radii.
  3. Loosen the pressure pipe from the pressure port.
  4. Attach the lifting equipment to the attachment point.
  5. Lift the pump out of the operating space. **CAUTION! Do not damage the connection cable! Pay attention to the connection cable when setting down the pump!**
  6. Thoroughly clean the pump (see section “Cleaning and disinfecting”).

#### 8.4.3 Clean and disinfect

- Wear protective equipment! Observe the work regulations.
    - Safety shoes: Protection class S1 (uvex 1 sport S1)
    - Breathing protection: Half mask 3M series 6000 with filter 6055 A2
    - Protective gloves: 4X42C + Type A (uvex protector chemical NK2725B)
    - Safety goggles: uvex skyguard NT
  - Use of disinfectants:
    - Use strictly according to the manufacturer’s instructions!
    - Wear protective equipment according to the manufacturer’s instructions!
  - Dispose of rinsing water in accordance with the local regulations, e.g. feed it into the sewer!
- ✓ Pump removed.
1. Ensure that the plug or bare cable ends are packed and stored in a watertight manner!
  2. Attach the lifting equipment to the attachment point on the pump.
  3. Lift the pump approximately 30 cm (10 in) above the ground.
  4. Spray the pump with clean water from top to bottom.
  5. Guide the water jet inwards through the discharge port to clean the impeller and pump interior.
  6. Disinfect the pump.
  7. Dispose of dirt residue on the ground, e.g. flush it into the sewer.
  8. Allow the pump to dry out.

## 9 Maintenance and repair

### 9.1 Personnel qualifications

- Electrical work: qualified electrician  
Person with appropriate technical training, knowledge and experience who can identify and prevent electrical hazards.
- Maintenance work: trained sewage technology professional  
Application/disposal of operating fluids used, basic engineering knowledge (installation/dismantling)

### 9.2 Operator responsibilities

- Provide the necessary protective equipment and make sure that the personnel wears it.
- Collect operating fluids in suitable tanks and dispose of properly.
- Dispose of protective clothing used in accordance with regulations.
- Use only original parts of the manufacturer. The use of any non-original parts releases the manufacturer from any liability.

- Collect any leakage of fluid and operating fluid immediately and dispose of it according to the locally applicable guidelines.
- Provide the tools required.
- If flammable solvents and cleaning agents are used, fire, naked flames and smoking are prohibited.
- Document maintenance tasks in the system’s inspection list.

## 9.3 Operating fluid

### 9.3.1 Oil types

- ExxonMobile: Marcol 52
- ExxonMobile: Marcol 82
- Total: Finavestan A 80 B (NSF-H1 certified)

### 9.3.2 Filling quantities

- Rexa FIT-V ... /2 ... : 900 ml (30 US.fl.oz.)
- Rexa FIT-V ... /4 ... : 1500 ml (51 US.fl.oz.)

## 9.4 Maintenance intervals

- Regularly carry out maintenance tasks.
- Contractually adjust maintenance intervals depending on the actual environmental conditions. Contact customer service.
- If strong vibrations occur during operation, check the installation.

### 9.4.1 Maintenance intervals for normal conditions

#### 1500 operating hours or after 5 years

- Visual inspection of the connection cables
- Visual inspection of accessories
- Visual inspection of the coating and housing
- Function test of monitoring devices
- Sealing chamber oil change **NOTICE! If a sealing chamber monitoring is installed, the oil is changed according to the indicator!**

#### 5000 operating hours or after 10 years

- Complete overhaul

### 9.4.2 Maintenance intervals for use in sewage lifting units

When the pump is used in sewage lifting units inside buildings or on plots of land, carry out maintenance intervals and measures in accordance with **DIN EN 12056-4!**

### 9.4.3 Maintenance intervals for harsh conditions

Under the following operating conditions, shorten the specified maintenance intervals in consultation with the customer service:

- Fluids with long-fibre components
- Turbulent inlet (e.g. due to air entry, cavitation)
- Highly corrosive or abrasive fluids
- Strongly gassing fluids
- Operation at an unfavourable duty point
- Pressure surges

If there are harsh operating conditions, it is recommended to conclude a maintenance contract.

## 9.5 Maintenance measures



### WARNING

#### Risk of injury from sharp edges!

Sharp edges can form on the impeller and suction port. There is a danger of cuts and similar injuries!

- Wear protective gloves!

Before starting maintenance work, meet the following requirements:

- Wear protective equipment! Observe the work regulations.

- Safety shoes: Protection class S1 (uvex 1 sport S1)
- Protective gloves: 4X42C (uvex C500 wet)
- Safety goggles: uvex skyguard NT

For detailed marking of frame and disc, see the section on “Personal protective equipment [▶ 5]”.

- The pump has been thoroughly cleaned and disinfected.
- Motor must have cooled down to the ambient temperature.
- Workplace:
  - Clean, good lighting and ventilation.
  - Firm and stable work surface.
  - Secured against falling over and slipping.

**NOTICE! Only perform the maintenance work described in these installation and operating instructions.**

### 9.5.1 Recommended maintenance measures

Regular inspection of power consumption and the operating voltage in all three phases is recommended for smooth operation. In normal operation, these values remain constant. Slight fluctuations depend on the characteristics of the fluid. Power consumption can provide an early indication of damage or malfunctions in the impeller, bearings or motor, which can be rectified. Larger voltage fluctuations strain the motor winding and can cause the pump to break down. Regular inspections can therefore largely prevent major secondary damage and reduce the risk of total breakdown. In this regard, it is recommended to use remote monitoring for regular inspections.

### 9.5.2 Visual inspection of the connection cable

Check connection cable for:

- Bubbles
- Cracks
- Scratches
- Abrasion
- Pinch points

If the connection cable is damaged:

- Decommission the pump immediately!
- Have the connection cable replaced by the customer service!

**CAUTION! Material damage! Damaged connection cables cause water to enter the motor. Water in the motor leads to total damage of the pump.**

### 9.5.3 Visual inspection of accessories

Accessories must be checked for:

- Correct fixation
- Smooth function
- Signs of wear, e.g. cracks caused by frequencies

Any defects detected must be repaired immediately or the accessories must be replaced.

### 9.5.4 Visual inspection of the coatings and housings

Coatings and housings must not show any damage. If there are defects, observe the following:

- Repair damaged coating. Order repair kits from the customer service.
- If housings are worn out, consult the customer service!

### 9.5.5 Function test of the monitoring device

To test resistances, the pump must be cooled down to the ambient temperature!

#### 9.5.5.1 Test the resistor of the temperature sensor

- ✓ Ohmmeter available.
- 1. Measure the resistance.
  - ⇒ Measured value **Bimetallic strip**: 0 ohms (passage).
  - ▶ Resistance checked. If the measured value deviates from the specification, consult the customer service.

#### 9.5.5.2 Testing the resistor of the external electrode for sealing chamber control

- ✓ Ohmmeter available.
- 1. Measure the resistance.
  - ⇒ Measured values “infinite ( $\infty$ )”: Monitoring device OK.
  - ⇒ Measured value  $\leq 30 \text{ k}\Omega$ : Water in oil. Change oil.
  - ▶ Resistance checked. If the measured value still deviates after the oil change, consult customer service.

### 9.5.6 Rotate impeller



#### WARNING

##### Risk of injury from sharp edges!

Sharp edges can form on the impeller and suction port. There is a danger of cuts and similar injuries!

- Wear protective gloves!

- ✓ Pump disconnected from mains.
- ✓ Protective equipment put on.
- 1. Place the pump on a firm surface in a horizontal position.
  - WARNING! Risk of hands being crushed. Make sure that the pump cannot roll away or slip!**
- 2. Slowly and carefully reach into the hydraulics housing from below and rotate the impeller.

### 9.5.7 Oil change in sealing chamber



#### WARNING

##### Operating fluid under pressure!

High pressure can build up in the motor! This pressure is released when the screw plugs are **opened**.

- If screw plugs are opened without due caution, they can be ejected at high speed!
- Hot operating fluid may spray out!
  - Wear protective equipment!
  - Allow the motor to cool down to ambient temperature before carrying out any work!
  - Adhere to the prescribed sequence of work steps!
  - Unscrew the screw plugs slowly.
  - As soon as the pressure escapes (audible whistling or hissing of air), stop turning the screw plug any further!
  - Only when the pressure has been completely released, fully unscrew the screw plug.

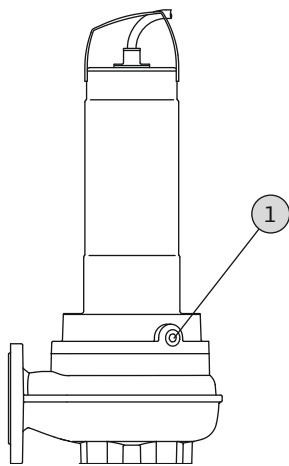

Fig. 8: Sealing chamber: Oil change

- |   |                            |
|---|----------------------------|
| 1 | Screw plug sealing chamber |
|---|----------------------------|
- ✓ Protective equipment used!
  - ✓ Pump has been removed, cleaned and disinfected.
1. Place the pump on a firm work surface in a horizontal position. The screw plug should face upwards.
  2. Secure the pump against falling over and slipping!
  3. Unscrew the screw plug slowly.
  4. When the pressure has been released, completely unscrew the screw plug.
  5. Position a suitable tank to collect the operating fluid.
  6. Drain the operating fluid: Rotate the pump until the opening points downwards.
  7. Check the operating fluid:
    - ⇒ Operating fluid clear: Operating fluid can be reused.
    - ⇒ Operating fluid contaminated (black): fill with new operating fluid.
    - ⇒ Operating fluid milky/cloudy: Water in oil. Minor leakage through the mechanical seal is normal. If the ratio of oil to water is less than 2:1, the mechanical seal may be damaged. Change the oil and check again four weeks later. If water is again present in the oil during the second check, contact customer service!
    - ⇒ Metal chips in the operating fluid: Contact the customer service!
  8. Pour in operating fluid: Rotate the pump until the opening points upwards. Pour the operating fluid into the opening.
    - ⇒ Comply with the specifications for the operating fluid type and quantity!
  9. Clean the screw plug, replace the seal ring and screw it back in. **Max. tightening torque: 8 Nm (5.9 ft-lb)!**

### 9.5.8 General overhaul

During the general overhaul, the motor bearings, shaft sealings, O-rings and connection cables are checked for wear and damage. Damaged components are replaced with original parts. This ensures correct operation.

The general overhaul is performed by the manufacturer or an authorised service centre.

## 10 Faults, causes and remedies



### WARNING

#### Risk of injury from rotating components!

No persons are allowed to be present in the working area of the pump. There is a risk of injury!

- Demarcate and cordon off the working area.
- If there are no persons in the working area, activate the pump.
- If persons enter the working area, switch off the pump immediately.

#### Fault: Pump does not start

1. Electricity supply interrupted or short-circuit/earth fault in the cable or motor winding.
  - ⇒ Have the connection and motor checked by a qualified electrician and replace if necessary.
2. Tripping of fuses, of the motor protection switch or the monitoring device
  - ⇒ Have the connection and the monitoring device checked by a qualified electrician and change it if necessary.
  - ⇒ Have the motor protection switches and fuses installed and adjusted according to the technical specifications by a qualified electrician and reset monitoring device.
  - ⇒ Check the impeller to make sure that it runs smoothly, clean the hydraulics if necessary.
3. The sealing chamber control (optional) has interrupted the electric circuit (connection-related)
  - ⇒ See "Fault: Mechanical seal leakage, sealing chamber control reports a fault and switches the pump off".

#### Fault: Pump starts up, motor protection trips after short period

1. Motor protection switch set incorrectly.
  - ⇒ Have the adjustment of the trigger checked and corrected by a qualified electrician.
2. Increased power consumption due to major voltage drop.
  - ⇒ Have the voltage of individual phases checked by a qualified electrician. Contact the electricity distribution network.
3. There are only two phases at the connection.
  - ⇒ Have the connection checked and corrected by a qualified electrician.
4. Excessive differences in voltage between the phases.
  - ⇒ Have the voltage of individual phases checked by a qualified electrician. Contact the electricity distribution network.
5. Incorrect direction of rotation.
  - ⇒ Have the connection corrected by a qualified electrician.
6. Increased power consumption through jammed hydraulics.
  - ⇒ Clean the hydraulics and check the inlet.
7. The density of the fluid is too high.
  - ⇒ Contact customer service.

#### Fault: Pump runs, there is no volume flow

1. There is no fluid.
  - ⇒ Check the inlet, open all gate valves.
2. Inlet clogged.
  - ⇒ Check the inlet and remove clogging.
3. Hydraulics jammed.
  - ⇒ Clean the hydraulics.
4. Pipe system on the pressure side or pressure hose clogged.
  - ⇒ Remove clogging and replace the damaged components if necessary.

- Intermittent operation.  
⇒ Check the switching system.

#### **Fault: Pump starts, duty point is not reached**

- Inlet clogged.  
⇒ Check the inlet and remove clogging.
- Slide valves on the pressure side closed.  
⇒ Completely open all gate valves.
- Hydraulics jammed.  
⇒ Clean the hydraulics.
- Incorrect direction of rotation.  
⇒ Have the connection corrected by a qualified electrician.
- Air cushion in the pipe system.  
⇒ Vent the pipe system.  
⇒ If air cushions occur frequently: Locate and prevent the air intake, if required install ventilation systems at specified locations.
- Pump pumping against excessive pressure.  
⇒ Open all gate valves on the pressure side completely.
- Signs of wear on the hydraulics.  
⇒ Have the components (impeller, suction port, pump housing) checked and replaced by customer service.
- Pipe system on the pressure side or pressure hose clogged.  
⇒ Remove clogging and replace the damaged components if necessary.
- Strongly gassing fluid.  
⇒ Contact customer service.
- The connection only has two phases.  
⇒ Have the connection checked and corrected by a qualified electrician.
- Excessive decrease in the fill level during operation.  
⇒ Check supply/capacity of the system.  
⇒ Have the switching points of the level control checked and adjusted if necessary.

#### **Fault: The pump does not run smoothly and is noisy**

- Improper duty point.  
⇒ Check the pump configuration and the duty point, contact customer service.
- Hydraulics jammed.  
⇒ Clean the hydraulics.
- Strongly gassing fluid.  
⇒ Contact customer service.
- There are only two phases at the connection.  
⇒ Have the connection checked and corrected by a qualified electrician.
- Incorrect direction of rotation.  
⇒ Have the connection corrected by a qualified electrician.
- Signs of wear on the hydraulics.  
⇒ Have the components (impeller, suction port, pump housing) checked and replaced by customer service.
- Motor bearings have worn.  
⇒ Inform customer service; send the pump back to the factory for overhauling.
- Pump is installed under tension.  
⇒ Check installation, install rubber compensators if necessary.

#### **Fault: Sealing chamber control reports fault or switches the pump off**

- Condensation water build-up due to extended storage or high temperature fluctuations.  
⇒ Operate the pump for a short period (max. 5 min.) without pencil electrode.
- Increased leakage when running in new mechanical seals.

⇒ Change the oil.

- Pencil electrode cable is defective.  
⇒ Replace the pencil electrode.
- Mechanical seal is defective.  
⇒ Inform customer service.

#### **Further steps for troubleshooting**

If the points listed here do not rectify the fault, contact customer service. Customer service can assist in the following ways:

- Telephone or written support.
- On-site support.
- Inspection and repair at the factory.

Costs may be incurred if you request customer services! Please contact customer services for more information.

## **11 Spare parts**

Spare parts are ordered via customer service. To avoid return queries and incorrect orders, the serial or article number must always be supplied. **Subject to change without prior notice!**

## **12 Disposal**

### **12.1 Oils and lubricants**

Operating fluids must be collected in suitable containers and disposed of in accordance with the locally applicable guidelines. Wipe up drips immediately!

### **12.2 Protective clothing**

Used protective clothing must be disposed off in accordance with the locally applicable guidelines.

### **12.3 Information on the collection of used electrical and electronic products**

Proper disposal and appropriate recycling of this product avoids environmental damage and risks to personal health.



## **NOTICE**

### **Disposal in domestic waste is prohibited!**

In the European Union this symbol may be included on the product, the packaging or the accompanying documentation. It means that the electrical and electronic products in question must not be disposed of along with domestic waste.

Please note the following points to ensure proper handling, recycling and disposal of the used products in question:

- Hand over these products at designated, certified collection points only.
- Observe the locally applicable regulations!

Please consult your local municipality, the nearest waste disposal site, or the dealer who sold the product to you for information on proper disposal. Further recycling information at <http://www.wilo-recycling.com>.

**Subject to change without prior notice!**









# wilo



Local contact at  
[www.wilo.com/contact](http://www.wilo.com/contact)

Pioneering for You

WILO SE  
Wilopark 1  
44263 Dortmund  
Germany  
T +49 (0)231 4102-0  
T +49 (0)231 4102-7363  
[wilo@wilo.com](mailto:wilo@wilo.com)  
[www.wilo.com](http://www.wilo.com)