

Wilo-Initial JET System



en Installation and operating instructions

Fig. 1

Initial Jet System 4-4-50

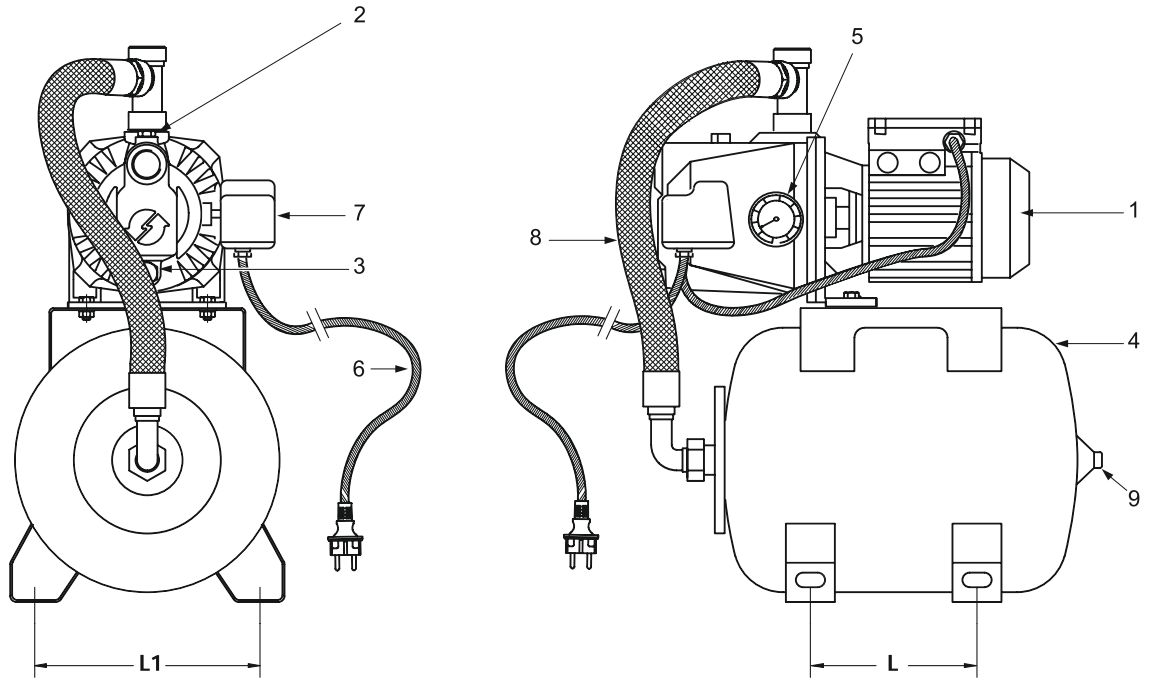

Initial Jet System 3-4-19

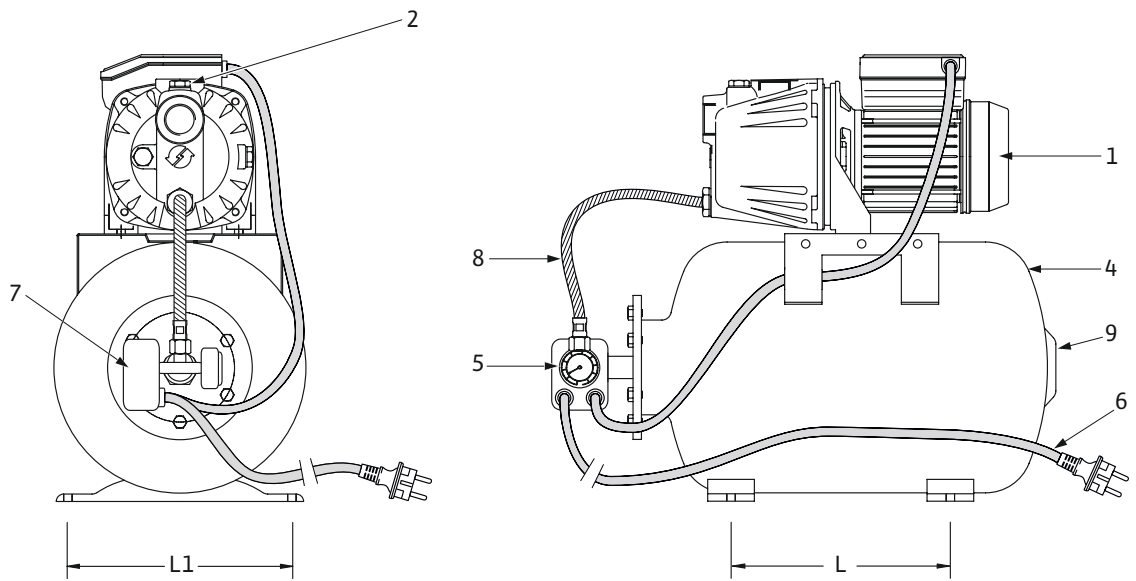
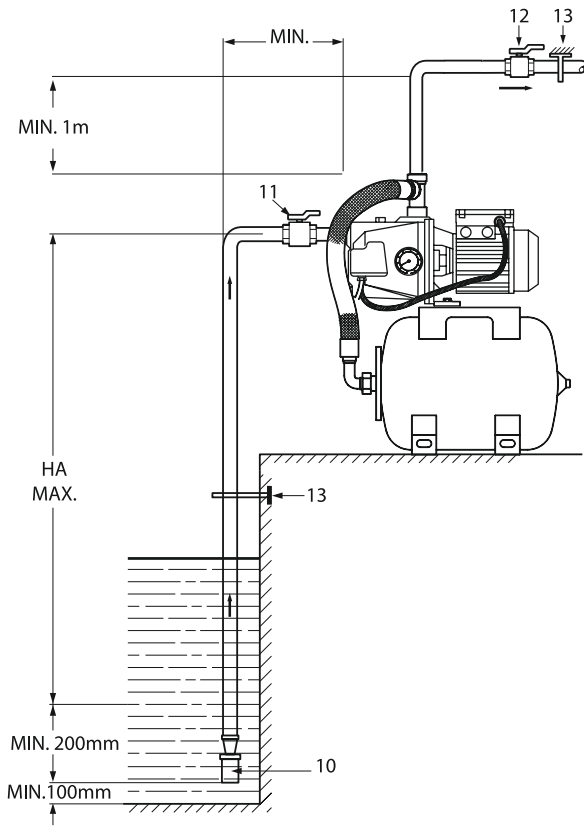

Fig. 2

Initial Jet System 4-4-50



Initial Jet System 3-4-19

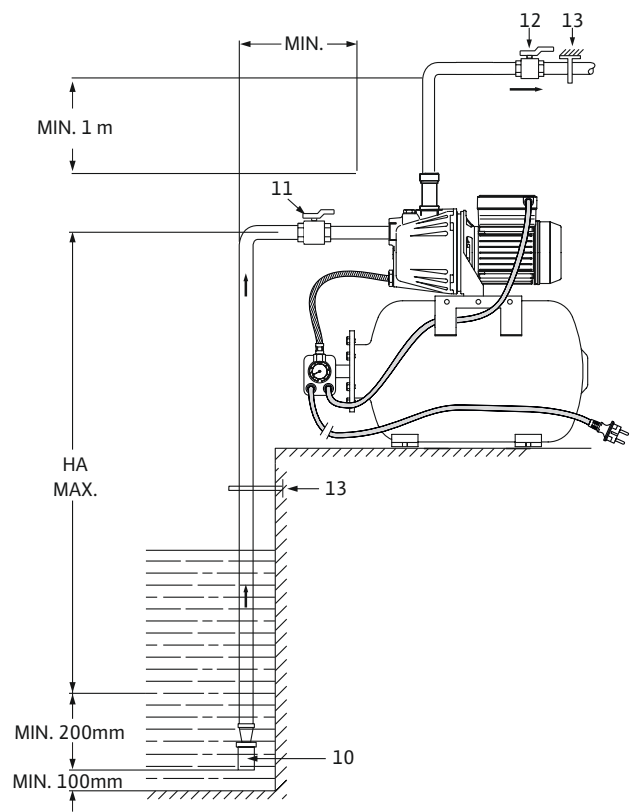

Fig. 3

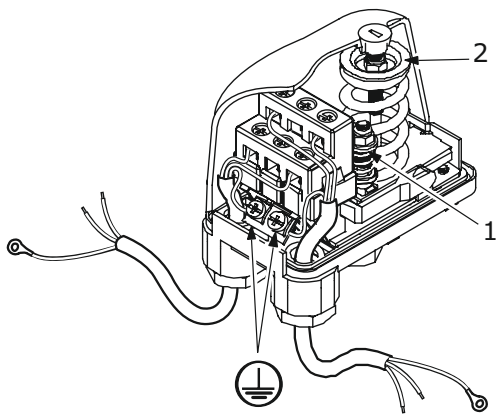
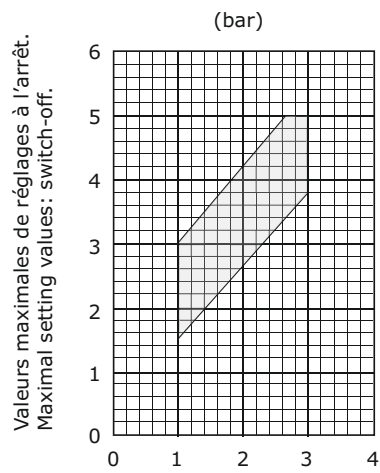

Fig. 4



Valeurs minimales de réglages au démarrage
Minimal setting values: switch-on.

1. General

1.1 About this document

The language of the original operating instructions is French. All other languages of these instructions are translations of the original operating instructions.

These installation and operating instructions are an integral part of the product. They must be kept readily available at the place where the product is installed. Strict adherence to these instructions is a precondition for the proper use and correct operation of the product.

These installation and operating instructions correspond to the relevant version of the product and the underlying safety standards valid at the time of going to print.

2. Safety

These operating instructions contain basic information which must be adhered to during installation, operation and maintenance. For this reason, these operating instructions must, without fail, be read by the service technician and the responsible specialist/operator before installation and commissioning.

It is not only the general safety instructions listed under the main point "safety" that must be adhered to but also the special safety instructions with danger symbols included under the following main points.

2.1 Symbols and signal words in the operating instructions

Symbols:



General danger symbol.



Danger due to electrical voltage.



NOTE:

Signal words:

DANGER! Acutely dangerous situation.

Non-observance results in death or the most serious of injuries.

WARNING! The user can suffer (serious) injuries. 'Warning' implies that (serious) injury to persons is probable if this information is disregarded.

CAUTION! There is a risk of damaging the product/unit. "Caution" implies that damage to the product is likely if this information is disregarded.

NOTE: Useful information on handling the product. It draws attention to possible problems. Information that appears directly on the product, such as

- Direction of rotation arrow,
 - Identifiers for connections,
 - Name plate,
 - Warningsticker
- must be strictly complied with and kept in legible condition.

2.2 Personnel qualification

The installation, operating and maintenance personnel must have the appropriate qualifications for this work. Area of responsibility, terms of reference and monitoring of the personnel are to be ensured by the operator. If the personnel are not in possession of the necessary knowledge, they are to be trained and instructed. This can be accomplished if necessary by the manufacturer of the product at the request of the operator.

2.3 Danger in the event of non-observance of the safety instructions

Non-observance of the safety instructions can result in risk of injury to persons and damage to the environment and the product/unit. Non-observance of the safety instructions results in the loss of any claims for damages.

In particular, non-observance can, for example, result in the following risks:

- Danger to persons from electrical, mechanical and bacteriological influences,
- Damage to the environment due to leakage of hazardous materials,
- Property damage,
- Failure of important product/unit functions,
- Failure of required maintenance and repair procedures.

2.4 Safety consciousness on the job

The safety instructions included in these installation and operating instructions, the existing national regulations for accident prevention together with any internal working, operating and safety regulations of the operator are to be complied with.

2.5 Safety instructions for the operator

This appliance is not intended for use by persons (including children) with reduced physical, sensory or mental capabilities, or lack of experience and knowledge, unless they have been given supervision or instruction concerning use of the appliance by a person responsible for their safety. Children should be supervised to ensure that they do not play with the appliance.

- If hot or cold components on the product/the unit lead to hazards, local measures must be taken to guard them against touching.
- Guards protecting against touching moving components (such as the coupling) must not be removed whilst the product is in operation.
- Leakages (e.g. from the shaft seals) of hazardous fluids (which are explosive, toxic or hot) must be led away so that no danger to persons or to the environment arises. National statutory provisions are to be complied with.
- Highly flammable materials are always to be kept at a safe distance from the product.
- Danger from electrical current must be eliminated. Local directives or general directives [e.g. IEC, VDE etc.] and local power supply companies must be adhered to.

2.6 Safety instructions for installation and maintenance work

The operator must ensure that all installation and maintenance work is carried out by authorised and qualified personnel, who are sufficiently informed from their own detailed study of the operating instructions.

Work on the product/unit must only be carried out when at a standstill. It is mandatory that the procedure described in the installation and operating instructions for shutting down the product/unit be complied with.

Immediately on conclusion of the work, all safety and protective devices must be put back in position and/or recommissioned.

2.7 Unauthorised modification and manufacture of spare parts

Unauthorised modification and manufacture of spare parts will impair the safety of the product/personnel and will make void the manufacturer's declarations regarding safety.

Modifications to the product are only permissible after consultation with the manufacturer. Original spare parts and accessories authorised by the manufacturer ensure safety. The use of other parts will absolve us of liability for consequential events.

2.8 Improper use

The operating safety of the supplied product is only guaranteed for conventional use in accordance with Section 4 of the operating instructions. The limit values must on no account fall under or exceed those specified in the catalogue/data sheet.

3. Transport and interim storage

When receiving the material, check that there has been no damage during the transport. If shipping damage has occurred, take all necessary steps with the carrier within the allowed time.



CAUTION! Outside influences may cause damages.

If the delivered material is to be installed later on, store it in a dry place and protect it from impacts and any outside influences (humidity, frost etc.).

4. Product and accessories

4.1 Application

The domestic water system is designed to pressurise a water network in which the pressure is too low or non-existent. For domestic application.

Water supply and distribution possible from a well, a stream or a tank.

4.2 Technical data

Max. flow rate	See name plate
Max. delivery head	7 m
Temperature range	+ 5 to 35 °C
Max. ambient temperature	+ 40 °C
DN suction / delivery	G1»
Mains voltage	1~230 V, ± 10 % (50Hz)
Setting range of start /stop pressure of the pump	3-4-19 = 1.4 / 2.8 bar 4-4-50 = 1.6 / 3.2 bar

4.3 Description (Fig. 1, 2)

- 1 – Pump
- 2 – Filling plug
- 3 – Drain plug
- 4 – Diaphragm pressure vessel
- 5 – Manometer
- 6 – Power cable with plug
- 7 – Pressure contactor
- 8 – Pump/diaphragm pressure vessel connecting hose
- 9 – Pressure valve
- HA– Maximum suction head
(See technical data)

Accessories (optional)

- 10 – Foot valve with strainer
(maximum opening width 1 mm)
- 11 – Suction valve
- 12 – Discharge valve
- 13 – Piping support

4.4 Motor protection

Thermal protection of motor integrated in winding; automatic reset.

4.5 Dry-running protection

We recommend protecting it by a suitable device (float switch, pressure switch, control box).

4.6 Operating principle

The pump in operation discharges water into the diaphragm pressure vessel, compressing the air in the tank. When the max. set pressure is reached, the pump stops.

The air presses on the diaphragm, driving water into the distribution pipe when a tap is opened.

When enough water is pumped off for the minimum pressure to be reached, the pump starts to deliver water and refill the diaphragm pressure vessel.

The pressure contactor (pos. 7) automates the operation of the domestic water system; the pressures can be read on the pressure gauge.

The storage of water in the diaphragm pressure vessel means that water can be pumped without starting the pump.

5. Installation and electrical connection

5.1 Place of installation

The domestic water system must be installed in a shelter or in a room which is easily accessible, normally ventilated, and protected from frost.

5.2 Installation

Install the system on a smooth, level floor or on a concrete foundation block with attachment by anchor bolts.

Place an insulating material (cork or reinforced rubber) under the concrete block to prevent any transmission of flowing-water noise.

TYPE	L	L1
JET System 4-4-50	230	305
JET System 3-4-19	182	220

5.3 Hydraulic connections

Water supply

- With a reinforced hose, a spiral wrap or a pipe.
- Water used for the domestic water system may be taken from:
 - a well –the pump’s max. suction head must be considered;
 - a storage tank.
- It is essential to provide a foot valve for the strainer in the case of a well or a stream.
- The diameter of the suction piping must never be smaller than that of the pump. Limit the horizontal length of the suction piping and avoid all causes of head losses (necking, bends, etc.).
- No air leak can be allowed in this suction piping.
- Use supports with collars for rigid pipes so that the pump does not bear the weight of the pipes.

Distribution

- By $\varnothing 1\frac{1}{2}$ - 26/34 threaded piping connected to the brass coupling on the pump outlet.
- Thoroughly seal the piping with suitable products.



CAUTION! Bear in mind that the altitude of the place of installation and the water temperature may reduce the suction head of the pump.

Altitude	Loss of head	Temperature	Loss of head
0 m	0 m w.g.	20°C	0.20 m w.g.
500 m	0.60 m w.g.	30°C	0.40 m w.g.
1000 m	1.15 m w.g.	40°C	0.70 m w.g.
1500 m	1.70 m w.g.		
2000 m	2.20 m w.g.		
2500 m	2.65 m w.g.		
3000 m	3.20 m w.g.		



CAUTION! In order to separate the domestic water system from the installation for adjustment purposes or other works, install valves (quarter-turn or similar) at both suction and discharge piping (Fig. 1, pos. 11, 12).

5.4 Electrical connection



DANGER! Connections and checks should be carried out by a qualified electrician, in compliance with current local standards.

Power supply network

Single-phase 230 V: connect using the cord (H07RN-F or equivalent) with normalised plug (Fig. 1, pos. 6).

DO NOT FORGET TO CONNECT TO EARTH.



DANGER! A connection error would damage the motor. The power cable must never touch the pipe or the pump; make sure that it is sheltered from any humidity.

6. Commissioning



CAUTION! The system must never be operated in a dry state, not even briefly.

6.1 Pressurisation of tank

Check the tank pressure and correct it if necessary by pressurising via the tank valve (Fig. 1, pos. 9). The pressure must be 0.3 bar less than the pump’s starting pressure.

6.2 Filling and venting

Pump under pressure

- Close the discharge valve.
- Unscrew and remove the filling plug.
- Gradually open the suction valve and proceed to fill the pump completely via the filling port.
- Screw the filling plug back when the water has flowed out and air has completely escaped.

Pump in suction mode

- Only one filling is enough for priming the pump.
- Open the discharge valve (pos. 12).
- Open the suction valve (pos. 11).
- Unscrew and remove the filling plug (pos. 2).
- Insert the funnel into the port, fill the pump slowly and completely.
- After water flows out and all air has escaped, filling is completed.
- Screw the plugs back in.

6.3 Adjustment of pressure contactor (Fig. 3, 4)

The adjustment of pressure contactor is made at factory. But it’s possible to change it. Proceed as follow:

- Unscrew the nut (pos. 1) of the setscrew for pressure difference.
- Adjust the pump’s switch-on pressure the nut (pos. 2).
- Adjust the setscrew for pressure difference (pos. 1) to obtain the impact pressure of the pump.



NOTE: The selection of the switch-on and switch-off points of the pump must be compatible with the operating range of the contactor (Fig. 4).

7. Maintenance

- The motor bearings are lubricated for life.
- The mechanical seal does not require any maintenance during operation.
- In the case of a longer shutdown or frost, it must be drained by unscrewing the bottom plug.



CAUTION! Fill the pump before restarting it. Do not let the pump run more than a few minutes with a closed discharge valve.

8. Faults, causes, remedies



DANGER! Switch the system OFF before doing any work on it!

Faults	Causes	Remedies
Pump does not start	No current	Check the current at the motor terminal
	Motor trip-out has been activated	Dismantle and replace the damaged motor parts
Priming of the pump is difficult	The strainer is not immersed	Immerse the strainer (min. 20 cm)
	The pump casing is not filled	Fill the pump
	Air entering through the suction pipe	Check the tightness of suction pipe and links
	Foot valve with strainer is not closed	Clean the valve
	Strainer at the suction side is obstructed	Clean the strainer
	Suction head too high	Check suction head (max. 7 m) and modify the installation
Pump is running but there is no flow	The internal units are obstructed by foreign bodies	Dismantle the pump and clean it
	The suction pipe is obstructed	Clean the entire piping
	Air entering through the suction piping	Check the tightness of the whole pipe up to the pump and tighten it
	No water in the pump	Reprime. Check the tightness of the foot valve
	The suction pressure is too low; this is generally accompanied by cavitation noises	Excessive losses of suction head or suction head is too large
	The motor's supply voltage is too low	Check the voltage at the motor terminals and the sections of the conductors
	The discharge valve is closed	Check the valve and open it
Insufficient pressure within the system	The discharge valve is partially open	Open it progressively and completely up to a stable pressure
	High head losses	Check the head loss
	Suction piping is partially obstructed	Check the piping and clean it
	The motor fails to run at its nominal speed (foreign bodies, wrong power supply, motor's axial alignment is faulty)	Dismantle the pump and correct the problem
The flow is irregular	The suction head (HA) is too high	Review the installation conditions described in this manual
	The suction pipe has a smaller diameter than the pump	Review the installation conditions described in this manual
	The strainer and suction piping are partially obstructed	Remove and clean it
Pump vibrates	Poorly secured on its frame	Check the screws of the stud bolts and tighten them fully
	Pump is obstructed by foreign bodies	Dismantle the pump and clean it
Unusual motor overheating	Pump is obstructed by foreign bodies	Dismantle the pump and clean it
	Wrong power supply	Check if the voltage at the connection is within the normalised tolerances
Motor trip-out activated	The ambient temperature is too high	Ensure air circulation around the unit. Protect the unit and install it in such a way that it is not directly exposed to the sun. The motor is designed to operate at an ambient temperature of up to + 40 °C.
	The voltage is too low	Check the current using an ammeter or set to the current indicated at the motor rating plate
	One phase is interrupted	Verify the connections of the power cord

9. Spare parts

All spare parts must be ordered through the Wilo customer service.

Please state all data shown on the rating plate with each order to avoid queries and incorrect orders.

10. Disposal

Information on the collection of used electrical and electronic products

Proper disposal and appropriate recycling of this product prevents damage to the environment and dangers to your personal health.



NOTICE: Disposal in domestic waste is forbidden !

In the European Union, this symbol can appear on the product, the packaging or the accompanying documentation. It means that the electrical and electronic products in question must not be disposed of along with domestic waste.

To ensure proper handling, recycling and disposal of the used products in question, please note the following points:

- Only hand over these products at designated, certified collecting points.
- Observe the locally applicable regulations! Please consult your local municipality, the nearest waste disposal site, or the dealer who sold the product to you for information on proper disposal. For further information on recycling, go to www.wilo-recycling.com.

Subject to technical alterations!



wilo



Local contact at
www.wilo.com/contact

Pioneering for You

WILO SE
Wilopark 1
D-44263 Dortmund
Germany
T +49(0)231 4102-0
F +49(0)231 4102-7363
wilo@wilo.com
www.wilo.com