

Wilo-Isar 2ECH1-L

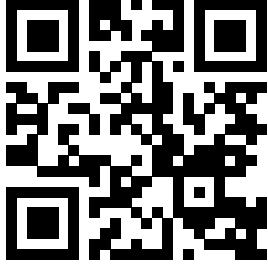

en Installation and operating instructions



Isar 2ECH1-L
<https://qr.wilo.com/500>

Table of Contents

1	General	4
1.1	About these instructions	4
1.2	Copyright	4
1.3	Subject to change.....	4
1.4	Exclusion from warranty and liability.....	4
2	Safety	4
2.1	Identification of safety instructions	4
2.2	Personnel qualifications.....	5
2.3	Electrical work	5
2.4	Transport.....	5
2.5	Installing/dismantling.....	6
2.6	During operation.....	6
2.7	Maintenance tasks.....	6
2.8	Operator responsibilities	6
3	Application/use	6
3.1	Intended use.....	6
3.2	Improper use.....	7
4	Product description	7
4.1	Type key.....	7
4.2	Technical data	7
4.3	Scope of delivery.....	7
4.4	Accessories	8
4.5	Components of the pressure-boosting system.....	8
4.6	Function	9
5	Transport and storage	10
5.1	Delivery.....	10
5.2	Transport.....	10
5.3	Storage	11
6	Installation and electrical connection	11
6.1	Installation location.....	11
6.2	Installation	11
6.3	Electrical connection.....	15
7	Commissioning	15
7.1	Preparatory work	16
7.2	Commissioning the system	17
8	Shutdown/dismantling	17
9	Maintenance	17
9.1	Checking the pressure-boosting system.....	17
10	Faults, causes and remedies	17
11	Spare parts	19
12	Disposal	19
12.1	Protective clothing	19
12.2	Information on the collection of used electrical and electronic products.....	19

1 General

1.1 About these instructions

These instructions form part of the product. Compliance with the instructions is essential for correct handling and use:

- Read the instructions carefully before all activities.
- Keep the instructions in an accessible place at all times.
- Observe all product specifications.
- Observe the markings on the product.

The language of the original operating instructions is German. All other languages of these instructions are translations of the original operating instructions.

1.2 Copyright

WILO SE © 2025

The reproduction, distribution and utilisation of this document in addition to communication of its contents to others without express consent is prohibited. Offenders will be held liable for payment of damages. All rights reserved.

1.3 Subject to change

Wilo shall reserve the right to change the listed data without notice and shall not be liable for technical inaccuracies and/or omissions. The illustrations used may differ from the original and are intended as an exemplary representation of the product.

1.4 Exclusion from warranty and liability

Wilo shall specifically not assume any warranty or liability in the following cases:

- Inadequate configuration due to inadequate or incorrect instructions by the operator or the client
- Non-compliance with these instructions
- Improper use
- Incorrect storage or transport
- Incorrect installation or dismantling
- Insufficient maintenance
- Unauthorised repairs
- Inadequate construction site
- Chemical, electrical or electrochemical influences
- Wear

2 Safety

This chapter contains basic information for the individual phases of the life cycle. Failure to observe this information carries the following risks:

- Injury to persons from electrical, mechanical and bacteriological factors as well as electromagnetic fields
- Environmental damage from discharge of hazardous substances
- Property damage
- Failure of important functions of the product

Failure to observe the information contained herein will result in the loss of claims for damages.

The instructions and safety instructions in the other chapters must also be observed!

2.1 Identification of safety instructions

These installation and operating instructions set out safety instructions for preventing personal injury and damage to property. These safety instructions are shown differently:

- Safety instructions relating to personal injury start with a signal word, are **preceded by a corresponding symbol** and are shaded in grey.



DANGER

Type and source of the danger!

Consequences of danger and instructions for avoidance.

- Safety instructions relating to property damage start with a signal word and are displayed **without** a symbol.

CAUTION

Type and source of the danger!

Consequences or information.

Signal words

- **DANGER!**
Failure to follow the instructions will result in serious injuries or death!

- **WARNING!**
Failure to follow the instructions can lead to (serious) injury!
- **CAUTION!**
Failure to follow the instructions can lead to potentially irreparable property damage as well as to total loss.
- **NOTICE!**
Useful information on handling the product

Markups

- ✓ Prerequisite
- 1. Work step/list
 - ⇒ Notice/instructions
 - ▶ Result

Symbols

These instructions use the following symbols:



General danger symbol



Danger caused by electric voltage



General warning symbol



Useful information

2.2 Personnel qualifications

- Personnel have been instructed on locally applicable regulations governing accident prevention.
- Personnel have read and understood the installation and operating instructions.
- Electrical work: qualified electrician
Person with appropriate technical training (according to EN 50110-1), knowledge and experience who can identify and prevent electrical hazards.
- Lifting work: trained specialist for the operation of lifting devices
Lifting equipment, lifting gear, attachment points
- Installation/dismantling must be carried out by a qualified technician who is trained in the use of the necessary tools and fixation materials.
- Operation/control: Operating personnel, instructed in the functioning of the complete system

2.3 Electrical work

- Observe applicable local regulations when connecting to the mains power supply.
- Comply with the requirements of the local energy supply company.
- Have electrical work carried out by a qualified electrician.
- Earth the device.
- Carry out the electrical connection according to the instructions of the switchgear and control device.
- Train personnel on how to make electrical connections.
- Train personnel on the options for switching off the device.
- Disconnect device from the mains and secure it against being switched on again without authorisation.
- Replace defective connection cables. Contact customer service.

2.4 Transport

- Wear the following protective equipment:
 - Safety footwear
 - Safety helmet (when using lifting equipment)
- Locally applicable laws and regulations on work safety and accident prevention must be complied with.
- Only use legally prescribed and approved lifting and hoisting gear.
- Select the lifting gear based on the prevailing conditions (weather, attachment point, load, etc.).
- Always attach the lifting gear to the attachment points.
- Ensure that the lifting gear is securely attached.
- Ensure that the hoisting gear is stable.
- Ensure a second person is present to coordinate the procedure if required (e.g. if the operator's field of vision is blocked).

- Standing under suspended loads is not permitted. Do **not** move suspended loads over workplaces where people are present.
- 2.5 Installing/dismantling**
- Wear the following protective equipment:
 - Safety footwear
 - Safety gloves for protection against cuts
 - Locally applicable laws and regulations on work safety and accident prevention must be complied with.
 - Disconnect device from the mains and secure it against being switched on again without authorisation.
 - All rotating parts must stop.
 - Clean the device thoroughly.
- 2.6 During operation**
- Wear protective equipment according to work regulations.
 - Demarcate and cordon off the working area.
 - No persons are allowed in the working area during operation.
 - Depending on the process, the product is activated and deactivated using separate controls. Product may automatically activate following power cuts.
 - Superior must be informed immediately of any faults or irregularities.
 - Operator must switch product off immediately if faults occur.
 - Open all gate valves in the inlet and pressure pipe.
 - Ensure protection against dry running.
- 2.7 Maintenance tasks**
- Wear the following protective equipment:
 - Safety footwear
 - Safety gloves for protection against cuts
 - Disconnect device from the mains and secure it against being switched on again without authorisation.
 - Ensure cleanliness, dryness and good lighting in the work area.
 - Only carry out maintenance tasks described in these installation and operating instructions.
 - Only original parts of the manufacturer may be used. The use of any non-original parts releases the manufacturer from any liability.
 - Collect any leakage of fluid and operating fluid immediately and dispose of it according to the locally applicable guidelines.
 - Clean the device thoroughly.
- 2.8 Operator responsibilities**
- Provide installation and operating instructions in a language which the personnel can understand.
 - Make sure that the personnel have received the required training for the specified work.
 - Provide protective equipment. Ensure that the protective equipment is worn by personnel.
 - Ensure that safety and information signs mounted on the device are always legible.
 - Train the personnel on how the system operates.
 - Eliminate any risk from electrical current.
 - Demarcate and cordon off the working area.
 - Define a personnel work plan for safe workflow.
 - Carry out a sound pressure measurement. From a sound-pressure level of 85 dB(A) upward, wear hearing protection. Include a note in the work regulations!
- Observe the following points when handling the device:
- Use is not permitted for persons under the age of 16.
 - Persons under the age of 18 must be supervised by a technician!
 - Use is not permitted for persons with limited physical, sensory or mental capacities!

3 Application/use

3.1 Intended use

The pressure-boosting system is used to maintain the pressure in a water distribution network and ensure water supply.

The pressure-boosting system is used in:

- residential buildings, offices, administrative buildings, hotels, hospitals, trade, industry

The fluid to be pumped must not chemically or mechanically corrode the materials used in the system and must not contain any abrasive or long-fibre constituents.

The pressure-boosting system is supplied with water via the municipal water supply network or via a replenishment reservoir.

A pressure reducer must be used for pressure fluctuations in the inlet pipe of more than 1 bar. The pressure downstream of the pressure reducer (back-pressure) is the basis for the total delivery head calculation of the pressure-boosting system.

For your safety

- Completely reading and following all instructions in these Installation and operating instructions.
- Observing the statutory accident prevention and environmental regulations.
- Complying with inspection and maintenance regulations.
- Complying with in-house regulations and instructions.

The pressure-boosting system is built according to the manufacturer's specifications as well as the state of the art and the recognised safety regulations. However, in the event of incorrect operation or misuse, danger to life and limb of the operator or third parties or damage to the system itself and other material assets may occur.

The pressure-boosting system may only be used in technically fault-free condition and in accordance with its intended use, in a safety-conscious and hazard-conscious manner and in compliance with these installation and operating instructions. Faults that may affect safety must be rectified immediately by qualified personnel.

3.2 Improper use**Possible misuse**

The pressure-boosting system is not designed for applications that are not explicitly intended for it by the manufacturer. This includes, in particular:

- Pumping fluids that chemically or mechanically attack the materials used in the system
- Pumping fluids that contain abrasive or long-fibre components
- Pumping fluids that are not intended for this purpose by the manufacturer

Persons under the influence of intoxicating substances (e.g. alcohol, drugs, narcotics) are not authorised to operate, maintain or modify the pressure-boosting system in any way.

Improper use

Improper use occurs when parts other than those specified in the intended use are processed in the pressure-boosting system. Modification of the components of the pressure-boosting system also leads to improper use.

All spare parts must comply with the technical requirements specified by the manufacturer. There is no guarantee that third-party parts are designed and manufactured in accordance with appropriate safety and operational requirements. This is always guaranteed when using original spare parts.

Modifications to the pressure-boosting system (mechanical or electrical changes to the function sequence) invalidate any liability on the part of the manufacturer for any resulting damage. This also applies to the installation and adjustment of safety devices and valves as well as the modification of load-bearing parts.

4 Product description**4.1 Type key**

Example	Wilo-Isar 2ECH1-L-404
Wilo	Brand name
Isar	Product family: pressure-boosting systems
2	Number of pumps
E	With frequency converter
CH1-L	Pump series designation (Medana CH1-L) (see pump documentation)
4	Rated volume flow of pump Q [m ³ /h]
04	Number of pump stages

4.2 Technical data

Mains voltage	1~ 230 V
Mains frequency	50 Hz
Power consumption	See rating plate
Rated current	See rating plate
Protection class	IP 54
Max. operating pressure	10 bar
Ambient temperature	0 °C to +50 °C
Fluid temperature	0 °C to +50 °C

4.3 Scope of delivery

- Pressure-boosting system
- Installation and operating instructions

4.4 Accessories

Accessories must be ordered separately as required. The accessories from the Wilo range include the following:

Required

- Diaphragm expansion tank

Optional

- Stop valve
- Flexible connection hoses
- Pressure reducer
- Counter flanges to match the nominal diameter of the manifold

4.5 Components of the pressure-boosting system



NOTICE

Observe the respective installation and operating instructions for the individual component.

Pressure-boosting system

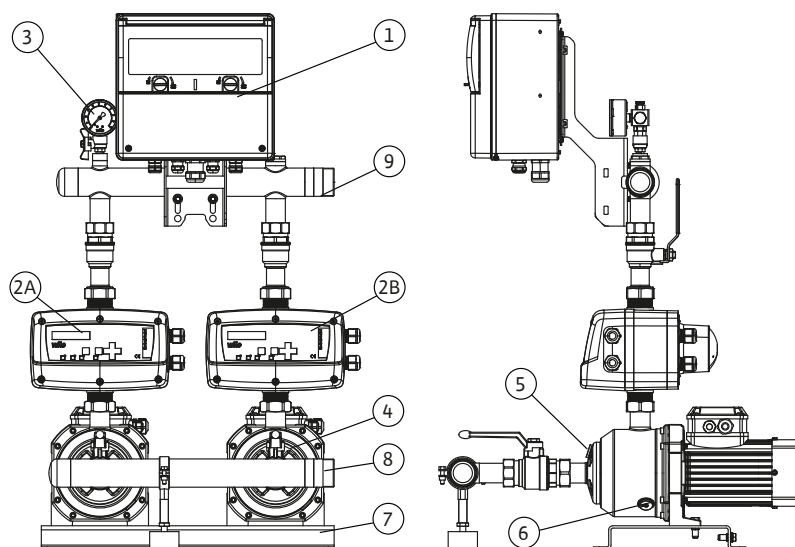

Fig. 1: Overview

Isar 2ECH1-L pressure-boosting system	
1	Mains connection box
2	Switchgear (2A: main switchgear, 2B: partner switchgear)
3	Pressure gauge
4	Pumps
5	Filler screw
6	Drainage screw
7	Base frame
8	Suction manifold
9	Discharge manifold

The pressure-boosting system is fitted with two non-self-priming multistage pumps. Each pump is controlled by a switchgear (frequency converter).

The pressure-boosting system is ready for connection and is fitted with the complete pipework.

Each pump is fitted with stop valves on the suction and discharge side.

The switchgear (Fig. 1, Item 2A, 2B) is mounted directly on the respective pump.

A mains connection box is used to separate and distribute the power supply to the pumps.

- Connections for the inlet and discharge line and the electrical mains connection must be produced on site.
- Observe the applicable provisions or standards for connection to the public water supply network. If applicable, observe the regulations of the water supply companies.
- Observe local conditions (e.g. excessive or strongly fluctuating suction pressure).

- The supplied accessories ordered separately must be installed.



NOTICE

Detailed instructions for the pump can be found in the enclosed installation and operating instructions for the pump.

Mains connection box

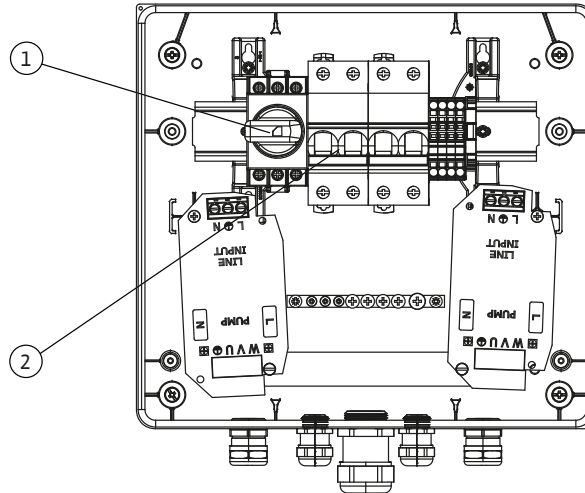

Fig. 2: Mains connection box

Mains connection box

1	Disconnect switch with mains connection terminals
2	Fuse holder for motor protection

The mains connection box ensures that the pumps are electrically protected and centralises the power supply to the system.

A disconnect switch for activation and additional fuses are located in the mains connection box. The mains connection box is mounted on the pipework with a mounting bracket.

Switchgear

A Wilo-ElectronicControl is used for control and regulation.



NOTICE

Detailed instructions for the switchgear can be found in the enclosed installation and operating instructions for the switchgear.

Diaphragm expansion tank

The diaphragm expansion tank has a buffer effect on the pressure sensor and prevents the control system from oscillating during commissioning and decommissioning. Leakages can be compensated for. A premature start of the pressure-boosting system is minimised.

4.6 Function

CAUTION

Property damage due to dry run!

Dry running can lead to the pump developing leakages and to motor overload.

- Ensure that the pump does not run dry to protect the mechanical seal and the plain bearings.

The switchgear of each pump ensures automatic control of the pressure-boosting system. Automation by the switchgears is based on the main/partner pump operation set at the factory.

The pump (Fig. 1, Item 2A) serves as the main pump and the pump (Fig. 1, Item 2B) as the partner pump. In main/partner pump operation, the nominal pressure is set on the main pump. The partner pump adopts the values.

If the water pressure on the discharge side is below the setpoint during commissioning, the main pump starts. If the water pressure is sufficiently high, the main pump stops and pump cycling takes place. The partner pump is the next pump to start.

The switchgear is fitted with pressure and volume flow sensors and a frequency converter. The switchgear makes it possible to maintain a constant pressure regardless of the volume flow and reduces the energy consumed by the pressure-boosting system in automatic mode.

The nominal pressure is set during installation and can be changed. If the main pump is in automatic mode, the partner pump is automatically switched to automatic mode.

5 Transport and storage



WARNING

Risk of injury from a lack of protective equipment!

Danger of (serious) injuries during work.

- Wear protective gloves to protect against cuts.
- Wear safety shoes.
- If lifting accessories are used, wear a safety helmet.



WARNING

Risk of injury from falling parts!

Never allow anyone to stand under suspended loads!

- Do not move the load over workplaces where persons are present.

CAUTION

Property damage due to incorrect loading!

Subjecting the pipes and valves to loads while in transit can result in leakages.

CAUTION

Property damage due to environmental influences!

The system can be damaged by environmental influences.

- Take suitable measures to protect the system from moisture, frost and heat as well as mechanical damage.

5.1 Delivery

The pressure-boosting system with 1 pump is delivered in a box. The pressure-boosting system is protected against moisture and dust.

The pressure-boosting system with 2 pumps is fixed to a pallet. The pressure-boosting system is foil-wrapped to protect it against moisture and dust.

- Observe transport and storage instructions attached to the packaging.
- On delivery and before removing the packaging, check the packaging for damage.

If damage is detected due to a fall or similar:

- Check the pressure-boosting system and accessories for possible damage.
- Notify the delivery company (forwarding agent) or customer service, even if you do not find any obvious damage to the pressure-boosting system or its accessories.

5.2 Transport

The pressure-boosting system is packed in plastic wrap to protect it against moisture and dirt.

- If the outer packaging is damaged or no longer present, apply suitable protection from humidity and dirt.
- Do not remove the outer packaging until you are at the installation site.
- If the system is transported again at a later date, fit new suitable protection against moisture and contamination.
- Demarcate and cordon off the working area.
- Keep unauthorised persons away from the working area.
- Use approved lifting slings: Polyester webbing slings.
- Attach lifting slings to base frame.

5.3 Storage

- Place the system on a firm and even surface.
- Ambient conditions: 0 °C to 50 °C, max. humidity: 50 %.
- Dry hydraulics and pipework before packing.
- Protect the system from humidity and dirt.
- Protect the system from direct exposure to sunlight.

6 Installation and electrical connection

6.1 Installation location

Requirements for the installation location:

- Dry, well ventilated and frost-resistant.
- Sufficiently sized floor drainage (with sewer connection).
- Free of harmful gases and secured against gas ingress.
- Maximum ambient temperature of +0 °C to 50 °C at a relative humidity of 50%.
- Horizontal and level installation surface.

Also note:

- Ensure adequate space for maintenance work. The pressure-boosting system must be freely accessible from at least two sides.
- Wilo advises against installation and operation near living rooms and bedrooms.

6.2 Installation



DANGER

Danger of death due to electrical current!

Improper conduct when carrying out electrical work can lead to death due to electric shock!

- Only have electrical connection established by an electrician approved by the local energy supply company.
- Observe applicable local regulations.
- Before swapping the phases, switch off the main switch of the system and secure it against unauthorised restarting.

6.2.1 Foundation/bearing surface

- Install the pressure-boosting system on a flat, level ground or on a concrete block.
- To ensure insulation against structure-borne noise from the building structure, decouple the concrete block from the base using cork or reinforced rubber.
- Use screws to fix the pressure-boosting system to the base.

6.2.2 Hydraulic connection and pipes

CAUTION

Property damage caused by dust caps or plugs that have not been removed!

Dust caps or plugs that have not been removed lead to clogging and damage the pump.

- Check all connections and remove any remaining leftover packaging, dust caps and plugs.

For connections to the public drinking water supply network, the requirements of the responsible local water supply company must be met.

Prerequisites

- Completion of all welding and soldering work
- Carrying out required rinsing
- If necessary, disinfect the pipeline system and the delivered pressure-boosting system (hygiene according to local regulations (in Germany, according to TrinkwV 2001))

Installation notes

- In order to be able to isolate the pressure-boosting system in the event of an intervention, install shut-off devices on the manifold.
- On-site piping installation must be completed voltage-free.
- To avoid distortion of the pipe adaptors, use compensators with length limitation or flexible connection pipes. This minimises the transmission of system oscillations to the building installation.
- In order to prevent the transmission of structure-borne noise to the building, do not fix the pipe clamps to the pressure-boosting system pipework.

Tank suction side

- Install the suction pipe with a slope of at least 2% to the pump.

- Prevent turbulence near the suction pipe. Install an anti-vortex strainer if necessary.
- Note pressure losses that may occur due to accessories (foot valve – strainer).
- Avoid counter-slopes that cause the formation of air pockets at the highest point.
- Install a compensation pipe that connects the discharge-side manifold to the suction pipes.

Turning the manifold

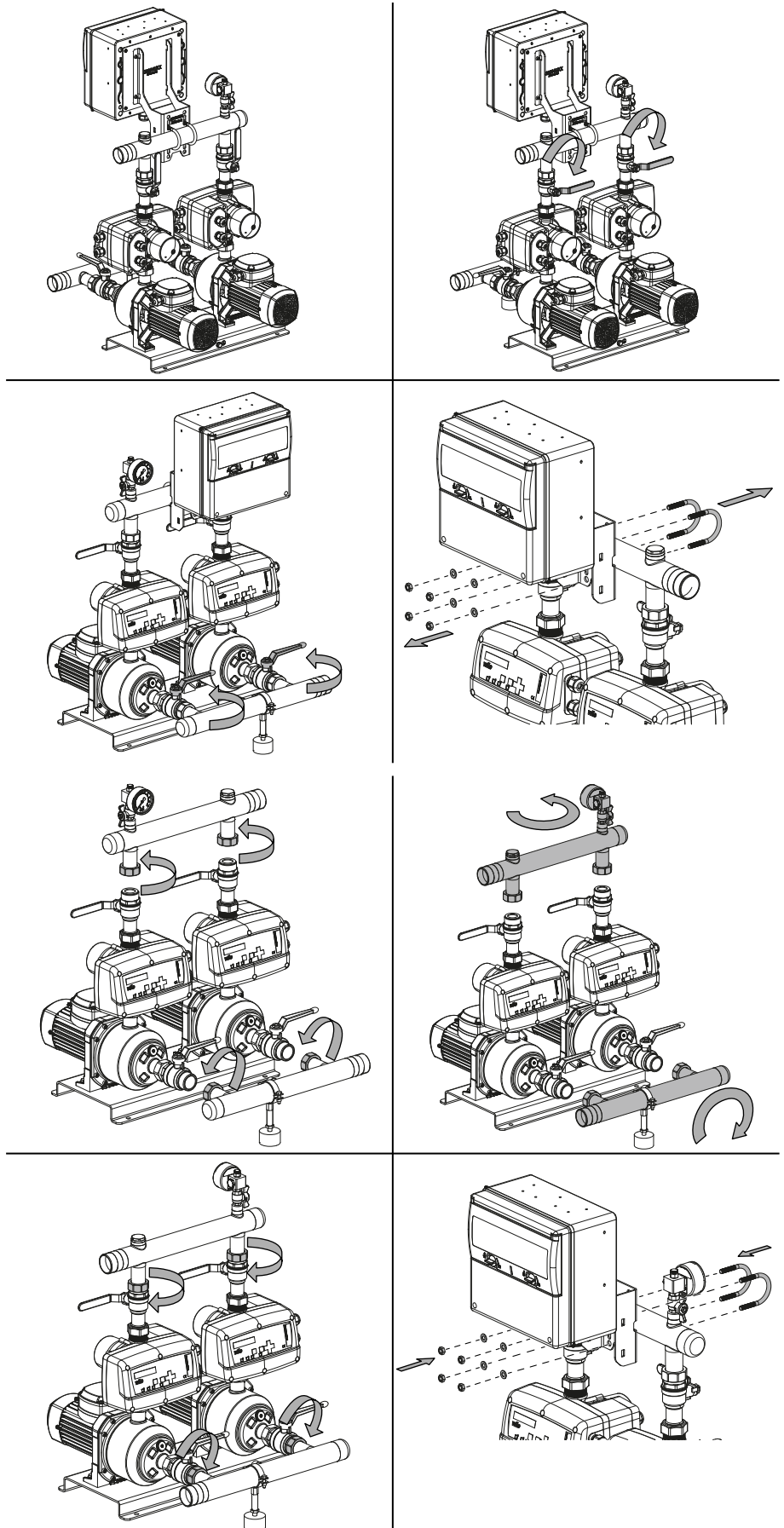

The system is prepared at the factory in such a way that the connection is on the right.

1. If the connection has to be made on the left side, turn the manifold pipework.
2. If the system is already filled with water, close the shut-off valves.
3. Loosen the mains connection box fastening.
4. Loosen the union nuts on the respective manifold.
5. Turn the manifold pipework in the relevant direction for the connection.
6. Mount the manifold pipework with the union nuts.
7. Replace the flat gaskets correctly.
8. Refit the mains connection box to the manifold pipework using the fastening.
9. Open all shut-off valves within the system.
10. The pressure transmitter/manometer kit can be rotated if necessary.

Flow resistance

Keep the flow resistance of the inlet and suction line as low as possible:

- Use short piping.
- Install pipes as horizontally as possible.
- Use pressure-resistant, vacuum-proof pipes.
- Use suitable nominal diameter (at least same size as system connection).
- Use few bends.
- Install sufficiently large shut-off valves.
- Avoid air intake upstream of the pressure-boosting system.
- Avoid automatic extractors.

Otherwise, the protection against low water level may be activated due to severe pressure losses in the event of high volume flows:

- Observe the NPSH of the pump
- Avoid pressure losses
- Avoid cavitation

Hygiene

Installations in the drinking water supply are subject to special hygiene requirements.

- Observe all locally applicable regulations and measures for drinking water hygiene.



NOTICE

The manufacturer recommends flushing the system for cleaning.

Preparing system flushing

1. Install a T-connector on the end pressure side of the pressure-boosting system (if there is a diaphragm expansion tank on the discharge side, immediately downstream of it) upstream of the next shut-off valve.
2. Fit the branch with a shut-off valve for draining the flushing fluid into the sewage system during flushing.
3. Nominal diameter of the branch must be adapted according to the maximum volume flow of the pressure-boosting system.
4. If it is not possible to achieve free drainage, such as when connecting a hose, the requirements of DIN 1988-200 must be observed.

6.2.3 Install accessories

Install the diaphragm expansion tank



NOTICE

Regular tests are required for diaphragm pressure expansion tanks in accordance with Directive 2014/68/EU (in Germany, also taking into account the Industrial Safety Regulation §§ 15(5) and 17 as well as Annex 5).

The pressure-boosting system must be fitted with at least one diaphragm expansion tank (8 litres).

- Mount the diaphragm expansion tank on the discharge-side manifold.

**NOTICE**

Observe the respective manufacturer's documentation for the component.

Install the compensators**NOTICE**

Compensators are subject to wear. It is necessary to regularly check for cracks or blisters, exposed fabric or other defects (see recommendations in DIN 1988).

For stress-free installation of the pressure-boosting system, connect the pipes using compensators. The compensators must be equipped with a structure-borne noise-insulating extension limiter to absorb the reaction forces that occur.

1. Install the compensators stress-free in the pipes. No alignment errors or pipe displacement must be compensated for with compensators.
2. Tighten screws evenly and diagonally. The ends of the screws must not project beyond the flange.
3. If welding work is done near the compensators, they must be covered for protection (sparks, radiated heat). Do not paint rubber component of compensators and protect against oil.
4. Compensators must be accessible for inspection at any time and must not be covered by the pipe insulation.

**NOTICE**

Observe the respective manufacturer's documentation for the component.

Install the flexible connection pipes**NOTICE**

Flexible connection pipes are subject to wear in operation. Regular checks for leakages or other defects are necessary (see recommendations of DIN 1988).

The flexible connection pipes in the Wilo range consist of a high-quality stainless steel corrugated hose with stainless steel braiding. In the case of pipes with threaded connections, use for stress-free installation of the pressure-boosting system and in the event of slight pipe displacement.

1. Fit the flat-sealing stainless steel screwed connection with female thread to the pressure-boosting system.
2. Install the male pipe thread on the onward pipework.

Observe the following during installation:

- Depending on the respective size, observe the maximum permissible deformations (bend radius RB and bend angle RW) according to the table.
- A suitable tool must be used to avoid kinking or twisting during installation.
- In the event of angular displacement of the pipes, fix the pressure-boosting system to the floor, taking into account suitable measures for reducing the structure-borne noise.
- Flexible connection pipes must be accessible for inspection at any time and must not be covered by the pipe insulation.

Nominal diameter Connection	Thread of screwed connection	Tapered male thread	Max. bend radius RB in mm	Max. bend angle BW in °
DN 32	Rp 1 $\frac{1}{4}$ "	Rp 1 $\frac{1}{4}$ "	250	60
DN 40	Rp 1 $\frac{1}{2}$ "	Rp 1 $\frac{1}{2}$ "	260	60
DN 50	Rp 2"	Rp 2"	300	50

Install the pressure reducer

- When pre-pressure fluctuations are so great that the pressure-boosting system must be shut down.
- In order to avoid pressure fluctuations when connected to the public drinking water supply, install a pressure reducer in the water supply line.



NOTICE

Refer to the data sheets and characteristic curves of the pressure-boosting system for the design of the data.



NOTICE

Observe the respective manufacturer's documentation for the component.

6.3 Electrical connection



DANGER

Danger of death due to electrical current!

Improper conduct when carrying out electrical work can lead to death due to electric shock!

- Only have electrical connection established by an electrician approved by the local energy supply company.
- Observe applicable local regulations.
- Before swapping the phases, switch off the main switch of the system and secure it against unauthorised restarting.



NOTICE

- For the electrical connection, observe the relevant installation and operating instructions.
- Observe the enclosed electrical circuit diagrams and connection diagrams.

- Technical electrical current type, voltage and frequency of the power supply network must match the details on the rating plate of the mains connection box.
- The mains connection cable for the pressure-boosting system with 1 pump is included in the scope of delivery. (Fig. 1, Item 6)
- Electrical connection cables for the pressure-boosting system with 2 pumps must be adequately dimensioned for the total power of the pressure-boosting system (see rating plate, installation and operating instructions, and electrical wiring diagrams).
- External fuse protection of the connection cable for the pressure-boosting system must be provided in accordance with the applicable local regulations in compliance with the details in the installation and operating instructions.
- As a protective measure, the pressure-boosting system with 2 pumps must be earthed according to regulations (i.e. according to the local regulations and circumstances). Connections intended for this purpose must be identified.
- The device conforms to standard IEC 61000-3-12 as long as the power supply for the connection is equipped with a minimum short-circuit power S_{sc} of 7.05. The person completing the installation or the operator must ensure – by consulting with the power supply operator, if necessary – that the device is only connected to a power supply with a short-circuit power S_{sc} rating of ≥ 7.05 .

7 Commissioning



DANGER

Danger of death due to electrical current!

Improper conduct when carrying out electrical work can lead to death due to electric shock!

- Only have electrical connection established by an electrician approved by the local energy supply company.
- Observe applicable local regulations.
- Before swapping the phases, switch off the main switch of the system and secure it against unauthorised restarting.



DANGER

Danger of death as supply pressure is too high!

Excessive supply pressure (nitrogen) in the diaphragm expansion tank can lead to damage or destruction of the tank and thus to personal injury.

- Observe the safety measures for handling pressurised vessels and technical gases.
- The pressures in these installation and operating instructions are given in **bar**. If other units of pressure measurement are used, convert the figures correctly.

CAUTION

Property damage due to dry run!

Dry running leads to the pump developing leakages and to motor overload.

- Ensure that the pump does not run dry to protect the mechanical seal and the plain bearings.



NOTICE

We recommend that the initial commissioning of the system is performed by the Wilo customer service department.

- Contact your dealer, your nearest Wilo representative or the Wilo customer service department.



NOTICE

Automatic activation after power cut

Depending on the process, the product is activated and deactivated using separate controls. The product may automatically be activated following power cuts.

7.1 Preparatory work

- Check that all on-site wiring has been performed correctly, in particular the earthing, prior to initial activation.
- Check that the pipe adaptors are not under stress.

7.1.1 Filling and venting

The pumps must be vented manually (manual mode). The switchgear must let each pump run at maximum speed. When the pump is vented, switch on automatic mode.

- Check water supply (adequately filled tank or adequate drinking water supply).
- Fill the system and carry out a visual inspection for leakages.
- Open the shut-off valve at each pump and in the suction and discharge line.
- Open the venting screws (Fig. 1, Item 2; Fig. 2, Item 5) of the pumps to allow the air to escape completely. Close the venting screw once the pumps have been fully vented.
- To check that the pump is functioning properly, press and hold down the “manual mode” button on the switchgear of a pump. If required, test pumps one after the other.

7.1.2 Fill diaphragm expansion tank

- Fill the diaphragm expansion tank to a pressure of 0.3 bar below the starting pressure of the pumps (nitrogen).

7.1.3 Checking the direction of rotation of the motor

Pressure-boosting system with 2 pumps

- Ensure that the pressure-boosting system is completely filled.
- Switch on the disconnect switch.
- Press the “manual mode” button on pump 1. Check the direction of rotation of the motor when the pump starts.
- Press the “manual mode” button on pump 2. Check the direction of rotation of the motor when the pump starts.
- If the direction of rotation of the motor needs to be changed, swap two phase cables of the motor.

7.2 Commissioning the system

The maximum operating pressure in the pressure-boosting system corresponds to the pressure of the zero volume flow of the pumps, which might be increased by the tap water pressure at the inlet of the pressure-boosting system

1. Switching on the switchgear.
 - ⇒ When the switchgear is switched on, it performs an automatic diagnostic test (10 seconds).
 2. Set switchgear to “Auto”.
 - ▶ The pressure-boosting system is in automatic mode.
- Refer to the installation and operating instructions for the pump and switchgear for a precise description.

8 Shutdown/dismantling

In case of maintenance or repair, take the pressure-boosting system out of operation as follows:

1. Switch off the voltage supply and secure it against unauthorised reactivation.
2. Close the shut-off valve upstream and downstream of the pressure-boosting system.
3. Shut off the diaphragm expansion tank at the throughflow fitting and drain it.
4. Drain the pressure-boosting system completely if necessary.

During a prolonged shutdown or in the case of frost:

- Drain the pressure-boosting system by removing the lower drainage screws from the pumps.



CAUTION

Property damage due to dry run!

The mechanical seals are damaged if the pumps run dry.

- Fill the pumps with water prior to commissioning.

9 Maintenance

9.1 Checking the pressure-boosting system

To guarantee maximum operational reliability at the lowest possible operating costs, we recommend regular inspection and maintenance of the pressure-boosting system (see DIN 1988). It is advisable to enter into a maintenance contract with a specialist company or with the Wilo customer service department.

Regularly carry out the following inspections:

- Inspection of the pressure-boosting system's readiness for operation.
- Inspection of the mechanical seal of the pumps. The mechanical seals need water for lubrication. Water may leak out of the gaskets slightly. In case of a larger water leak, replace the mechanical seal.
- Four times a year: Inspection of the diaphragm expansion tank (optional or accessories) for correct supply pressure setting and impermeability.

10 Faults, causes and remedies



DANGER

Danger of death due to electrical current!

The external electrical power supply is also present at the terminals when the main switch is switched off!

- Disconnect the external power supply before any work.
- Electrical work must be carried out by a qualified electrician.
- Observe local regulations.



WARNING

Risk of injury due to improper repair!

- Only allow repairs to be carried out by qualified personnel.



NOTICE

- The general safety instructions must be observed during any maintenance or repair work.
- Observe the installation and operating instructions for the pumps and switchgear.



NOTICE

- Alarms: See installation and operating instructions of the switchgear.

Fault	Cause	Remedy
A pump does not pump properly Two pumps do not pump properly	Air intake on the suction side	Check all connections on the suction line for leaks. Check that the suction level in the tank is covered with water.
	Strainer on the foot valve of the tank leaky or clogged	Check that the valve is sealed, replace if necessary.
	High pressure loss during suction	Calculate pressure losses and ensure that they correspond to the NPSH of the pump.
	Inadequate or no pressure of the municipal water supply network	If this occurs repeatedly, install additional tank.
	Negative suction head in tank too high	Ensure that the minimum fill level in the tank is compatible with the NPSH value of the pumps.
A pump is not running Two pumps are not running	Clogged suction line or clogged valve on the manifold	Check valve position and clean valve if necessary. Check pipe and clean if necessary.
	Thermal motor protection has triggered	Replace fuses. Check mains voltage at each pump for correctness. Check the direction of rotation, the coupling or current consumption of the affected motor. If this electric current is much higher than that of the motor, replace the motor.
	Pump shaft blocked	Disconnect the power supply to the mains connection box and check that the shaft rotates freely. If the shaft is blocked, disassemble the pump.
	Winding error	Disconnect the affected terminal strip of the motor from the mains supply and check the insulation of the earth's stator. Replace the motor if necessary.

Fault	Cause	Remedy
Pressure on the discharge side too low	Volume flow of the entire system is higher than the product capacity.	Replace the product with a suitable product (contact customer service).
	One or both pumps ran dry	Check whether the tank strainer is taking in air. Check whether the tank filling is too close to the strainer.
	Pressure of the municipal water supply network lower than the intended minimum pressure	Contact the water supply company. Replace product. Contact Wilo.
	Pump blocked by foreign objects.	Dismantle the pump and clean it.
	Power supply of the motors not sufficient	Check the power supply at the motor terminals.
Frequent pump starts	Incorrect nominal pressure	Check setting.
	Insufficient capacity of the system	Install additional tank.
	No air in the tank	Fill the tank. Replace diaphragm expansion tank.
Automatic mode defective	Cable break	Check connection of the terminal strip for the mains connection box.

- If the fault cannot be remedied, contact Wilo factory customer service.

11 Spare parts

Spare parts are ordered via customer service. To avoid return queries and incorrect orders, the serial or article number must always be supplied. **Subject to change without prior notice!**

12 Disposal

12.1 Protective clothing

Used protective clothing must be disposed off in accordance with the locally applicable guidelines.

12.2 Information on the collection of used electrical and electronic products

Proper disposal and appropriate recycling of this product avoids environmental damage and risks to personal health.



NOTICE

Disposal in domestic waste is prohibited!

In the European Union this symbol may be included on the product, the packaging or the accompanying documentation. It means that the electrical and electronic products in question must not be disposed of along with domestic waste.

Please note the following points to ensure proper handling, recycling and disposal of the used products in question:

- Hand over these products at designated, certified collection points only.
- Observe the locally applicable regulations!

Please consult your local municipality, the nearest waste disposal site, or the dealer who sold the product to you for information on proper disposal. Further recycling information at <http://www.wilo-recycling.com>.









wilo



Local contact at
www.wilo.com/contact

Pioneering for You

WILO SE
Wilopark 1
44263 Dortmund
Germany
T +49 (0)231 4102-0
T +49 (0)231 4102-7363
wilo@wilo.com
www.wilo.com