

Wilo-EMU KS



en Installation and operating instructions



EMU KS
<https://qr.wilo.com/716>

Table of contents

1 General	4	9.1 Personnel qualifications	25
1.1 About these instructions	4	9.2 Operator responsibilities	25
1.2 Copyright	4	9.3 Operating fluid	25
1.3 Subject to change.....	4	9.4 Maintenance intervals.....	26
1.4 Exclusion from warranty and liability.....	4	9.5 Maintenance measures.....	26
2 Safety	4	10 Faults, causes and remedies	27
2.1 Identification of safety instructions	4	11 Spare parts	29
2.2 Personnel qualifications.....	6	12 Disposal	29
2.3 Electrical work	6	12.1 Oils and lubricants	29
2.4 Monitoring devices	6	12.2 Protective clothing.....	29
2.5 Fluids hazardous to health	6	12.3 Information on the collection of used electrical and elec- tronic products.....	29
2.6 Transport.....	6	13 Appendix	30
2.7 Installing/dismantling.....	7	13.1 Ex rating	30
2.8 During operation.....	7		
2.9 Maintenance tasks.....	7		
2.10 Operating fluid	7		
2.11 Operator responsibilities	7		
3 Application/use	8		
3.1 Intended use.....	8		
3.2 Improper use.....	8		
4 Product description	8		
4.1 Design.....	8		
4.2 Monitoring devices	9		
4.3 Operating modes	10		
4.4 Operation with frequency converter	10		
4.5 Operation in an explosive atmosphere	10		
4.6 Technical data	10		
4.7 Type key	11		
4.8 Scope of delivery.....	11		
4.9 Accessories	12		
5 Transportation and storage	12		
5.1 Delivery.....	12		
5.2 Transport.....	12		
5.3 Storage	13		
6 Installation and electrical connection	13		
6.1 Personnel qualifications.....	13		
6.2 Installation types	13		
6.3 Operator responsibilities	14		
6.4 Installation	14		
6.5 Electrical connection	16		
7 Commissioning	20		
7.1 Personnel qualifications.....	20		
7.2 Operator responsibilities	20		
7.3 Direction of rotation check (for three-phase current mo- tors only)	20		
7.4 Operation in an explosive atmosphere	21		
7.5 Before switching on.....	22		
7.6 Switching on and off	22		
7.7 During operation.....	22		
8 Shut-down/dismantling	23		
8.1 Personnel qualifications.....	23		
8.2 Operator responsibilities	23		
8.3 Shut-down.....	23		
8.4 Removal.....	23		
9 Maintenance and repair	25		

1 General

1.1 About these instructions

These instructions form part of the product. Compliance with the instructions is essential for correct handling and use:

- Read the instructions carefully before all activities.
- Keep the instructions in an accessible place at all times.
- Observe all product specifications.
- Observe the markings on the product.

The language of the original operating instructions is German. All other languages of these instructions are translations of the original operating instructions.

1.2 Copyright

WILO SE © 2025

The reproduction, distribution and utilisation of this document in addition to communication of its contents to others without express consent is prohibited. Offenders will be held liable for payment of damages. All rights reserved.

1.3 Subject to change

Wilo shall reserve the right to change the listed data without notice and shall not be liable for technical inaccuracies and/or omissions. The illustrations used may differ from the original and are intended as an exemplary representation of the product.

1.4 Exclusion from warranty and liability

Wilo shall specifically not assume any warranty or liability in the following cases:

- Inadequate configuration due to inadequate or incorrect instructions by the operator or the client
- Non-compliance with these instructions
- Improper use
- Incorrect storage or transport
- Incorrect installation or dismantling
- Insufficient maintenance
- Unauthorised repairs
- Inadequate construction site
- Chemical, electrical or electrochemical influences
- Wear

2 Safety

This section contains basic information about the individual stages in the life cycle of the pump. Failure to observe this information leads to:

- Danger to persons
- Danger to the environment
- Property damage
- Loss of claims for damages

2.1 Identification of safety instructions

These installation and operating instructions set out safety instructions for preventing personal injury and damage to property. These safety instructions are shown differently:

- Safety instructions relating to personal injury start with a signal word, are **preceded by a corresponding symbol** and are shaded in grey.



DANGER

Type and source of the danger!

Consequences of the danger and instructions for avoidance.

- Safety instructions relating to property damage start with a signal word and are displayed **without** a symbol.

CAUTION

Type and source of the danger!

Consequences or information.

Signal words

- **DANGER!**
Failure to observe the safety instructions will result in serious injuries or death!
- **WARNING!**
Failure to follow the instructions can lead to (serious) injuries!
- **CAUTION!**
Failure to follow the instructions can lead to property damage and a possible total loss.

- **NOTICE!**
Useful information on handling the product

Symbols

These instructions use the following symbols:

-  Danger of electric voltage
-  Danger of bacterial infection
-  Danger of explosion
-  General warning symbols
-  Warning of crushing
-  Warning of cutting injuries
-  Warning of hot surfaces
-  Warning of high pressure
-  Warning of suspended loads
-  Personal protective equipment: Wear a safety helmet
-  Personal protective equipment: Wear foot protection
-  Personal protective equipment: Wear hand protection
-  Personal protective equipment: Wear mouth protection
-  Personal protective equipment: Wear safety goggles
-  Autonomous work prohibited! A second person must be present.
-  Useful information

Markups

- ✓ Prerequisite
- 1. Work step/list
 - ⇒ Notice/instructions
 - ▶ Result

Identifying cross references

The name of the section or table is in inverted commas [“ ”]. The page number follows in square brackets [].

2.2 Personnel qualifications

- Personnel have been instructed on locally applicable regulations governing accident prevention.
- Personnel have read and understood the installation and operating instructions.
- Electrical work: qualified electrician
Person with appropriate technical training, knowledge and experience who can identify and prevent electrical hazards.
- Installation/dismantling work: trained sewage technology professional
Fixation and pipework in wet well and dry well installation, lifting equipment, basic knowledge of wastewater facilities
- Maintenance work: trained sewage technology professional
Application/disposal of operating fluids used, basic engineering knowledge (installation/dismantling)
- Lifting work: trained specialist for the operation of lifting devices
Lifting equipment, lifting gear, attachment points

Children and persons with limited abilities

- Persons under the age of 16: Use of this product is prohibited.
- Persons under the age of 18: Supervise them during use of the product (supervisor)!
- Persons with limited physical, sensory or mental capacities: Use of this product is prohibited!

2.3 Electrical work

- Electrical work must be carried out by a qualified electrician.
- Disconnect device from the mains and secure it against being switched on again without authorisation.
- Observe applicable local regulations when connecting to the mains power supply.
- Comply with the requirements of the local energy supply company.
- Train personnel on how to make electrical connections.
- Train personnel on the options for switching off the device.
- Observe the technical information in these installation and operating instructions as well as on the rating plate.
- Earth the device.
- Observe provisions for connection to the electrical switching system.
- Comply with the specifications on electro-magnetic compatibility when using electronic start-up controllers (e.g. soft starter or frequency converter). If required, take special measures into account (e.g. shielded cables, filters, etc.).
- Replace defective connection cables. Contact customer service.

2.4 Monitoring devices

The following monitoring devices must be provided on-site:

Circuit breaker

- Design the power and switching characteristics of the circuit breakers according to the rated current of the connected product.
- Observe local regulations.

Motor protection switch

- Product without plug: install a motor protection switch!
The minimum requirement is a thermal relay/motor protection switch with temperature compensation, differential trip and reactivation lock according to local regulations.
- Instable mains supply systems: if necessary, install further protective devices on-site (e.g. overvoltage, undervoltage or phase failure relays, etc.).

Residual-current device (RCD)

- Install a residual-current device (RCD) in accordance with the regulations of the local energy supply company.
- If people can come into contact with the device and conductive fluids, install a residual-current device (RCD).

2.5 Fluids hazardous to health

Hazardous germs form in sewage or in stagnant water. There is a danger of bacterial infections!

- Wear protective equipment!
- Clean and disinfect the product thoroughly after removal!
- Inform all persons about the pumped fluid and the danger it poses!

2.6 Transport

- Locally applicable laws and regulations on work safety and accident prevention must be complied with.
- Always carry the product by the handle!
- Always attach the lifting gear to the attachment points.
- Ensure that the lifting gear is securely attached.

- 2.7 Installing/dismantling**
- Locally applicable laws and regulations on work safety and accident prevention must be complied with.
 - Disconnect device from the mains and secure it against being switched on again without authorisation.
 - All rotating parts must stop.
 - Ensure enclosed spaces have sufficient ventilation.
 - When working in enclosed spaces, a second person must be present for safety reasons.
 - Toxic or asphyxiating gases may build up in enclosed spaces or buildings. Observe protective measures in accordance with work regulations, e.g. carry a gas detector with you.
 - Clean the device thoroughly.
 - If the product has been used in fluids that are hazardous to health, disinfect the product!
- 2.8 During operation**
- Demarcate and cordon off the working area.
 - No persons are allowed in the working area during operation.
 - Depending on the process, the product is activated and deactivated using separate controls. The product may automatically be activated following power cuts.
 - If the motor emerges, the motor housing can heat up to above 40 °C (104 °F).
 - Superior must be informed immediately of any faults or irregularities.
 - The product must be switched off immediately if faults occur.
 - Never reach into the suction port. The rotating parts can crush and sever limbs.
 - Open all gate valves in the inlet and pressure pipe.
 - Ensure minimum water submersion by using dry-running protection.
 - Sound-pressure level depends on several factors (installation, duty point, etc.). Measure the current noise level under operating conditions. Wear hearing protection at noise levels of 85 dB(A) and over. Demarcate the working area!
- 2.9 Maintenance tasks**
- Disconnect device from the mains and secure it against being switched on again without authorisation.
 - Clean the device thoroughly.
 - If the product has been used in fluids that are hazardous to health, disinfect the product!
 - Carry out maintenance work in a clean, dry and well-lit place.
 - Only carry out maintenance tasks described in these installation and operating instructions.
 - Only original parts of the manufacturer may be used. The use of any non-original parts releases the manufacturer from any liability.
 - Collect any leakage of fluid and operating fluid immediately and dispose of it according to the locally applicable guidelines.
- 2.10 Operating fluid**
- The following white oils are used:
- ExxonMobile: Marcol 52
 - ExxonMobile: Marcol 82
- General remarks**
- Absorb leakages immediately.
 - If major leakages occur, contact customer service.
 - If the seal is defective, the oil enters the pumped fluid.
- First aid measures**
- **Skin contact**
 - Rinse skin areas thoroughly with soap and water.
 - If skin irritation occurs, consult a doctor.
 - In case of contact with open skin, consult a doctor!
 - **Eye contact**
 - Remove the contact lenses.
 - Rinse eye thoroughly with water.
 - If eye irritation occurs, consult a doctor.
 - **Inhalation**
 - Remove from the contact area!
 - Create air exchange!
 - If the respiratory tract becomes irritated or there is dizziness or nausea, consult a doctor immediately!
 - **Ingestion**
 - Consult a doctor **immediately!**
 - **Do not** induce vomiting!
- 2.11 Operator responsibilities**
- Provide installation and operating instructions in a language which the personnel can understand.
 - Make sure that the personnel have received the required training for the specified work.
 - Provide protective equipment. Ensure that the protective equipment is worn by personnel.
 - Ensure that safety and information signs mounted on the device are always legible.

3 Application/use

3.1 Intended use

Submersible pumps are suitable for pumping:

- Wastewater
- Fluids containing abrasive content (e.g. sand, gravel).

3.2 Improper use



DANGER
Explosion due to pumping of explosive fluids!
 Pumping of highly flammable and explosive fluids (gasoline, kerosene, etc.) in pure form is strictly prohibited. There is a risk of fatal injury due to explosion! The pumps are not designed for these fluids.



DANGER
Danger due to fluids hazardous to health!
 If the pump is used in fluids hazardous to health, decontaminate the pump after dismantling and before carrying out any other work! There is a risk of fatal injury! Observe the specifications in the work regulations! The operator must make sure that the personnel have received and read the work regulations!

The submersible pumps must **not be used** for pumping:

- Drinking water
- Sewage, with or without faeces
- Fluids containing hard components (such as stones, wood, metal, etc.)
- Fluids with dry matter

Intended use also includes compliance with this manual. Any other use is regarded as non-compliant with the intended use.

4 Product description

4.1 Design

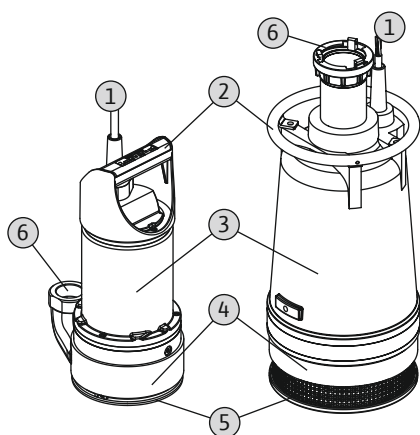

Fig. 1: Overview EMU KS

4.1.1 Hydraulics

Submersible drainage pump as a submersible monobloc unit for continuous duty in wet well installation.

1	Power supply cable
2	Handle/attachment point
3	Up to size 20: Motor housing
3	From size 24: Cooling jacket
4	Hydraulics housing
5	Suction port with suction strainer
6	Pressure port

Centrifugal hydraulics with semi-open, multi-channel impeller and vertical threaded connection on the pressure side. A Storz coupling is fitted to the pressure connection. The hydraulics are **not** self-priming, in other words, the fluid must flow in either automatically or with supply pressure.

4.1.2 Motor

EMU KS...

For the single-phase current or three-phase current version, self-cooling submersible motors are used as the drive. Up to size 20, cooling is by means of an oil filling in the motor compartment and from size 24 by sheath current cooling. The waste heat is transferred directly to the fluid via the motor housing. The motor can be used in continuous duty both immersed and non-immersed. The connection cable is equipped with a shockproof plug for the single-phase current version and with a CEE plug for the three-phase current version. In single-phase current motors, the operating capacitor is integrated into the plug.

EMU KS... Ex

The system is driven by surface-cooled submersible motors in three-phase current version. The motor is cooled by the fluid around it. The waste heat is transferred directly to the fluid via the motor housing. The motor may emerge during operation. The connection cable is longitudinally sealed watertight and has bare cable ends or is equipped with a CEE plug.

4.1.3 Material

EMU KS...

- Pump housing: EN-GJL-250 (ASTM A48 Class 35/40B)
- Impeller: EN-GJL-250 (ASTM A48 Class 35/40B) or EN-GJS-500-7 (ASTM A536 70-50-05)
- Motor housing: G-ALSi12
- Cooling jacket (from size 24): G-ALSi12
- Seal on the motor side: C/Al₂O₃
- Seal on the fluid side: SiC/SiC
- Seal, static: FPM (FKM)

NOTICE! In the "GG" version, the motor housing is also made from EN-GJL-250 (ASTM A48 Class 35/40B).

EMU KS... Ex

- Pump housing: EN-GJL-250 (ASTM A48 Class 35/40B)
- Impeller: EN-GJL-250 (ASTM A48 Class 35/40B) or EN-GJS-500-7 (ASTM A536 70-50-05)
- Motor housing: EN-GJL-250 (ASTM A48 Class 35/40B)
- Seal on the motor side: SiC/SiC
- Seal on the fluid side: SiC/SiC
- Seal, static: FPM (FKM)

4.1.4 Fitted accessories

Float switch

In the "S" version and "DMS" version, the pump is equipped with a float switch. Depending on the fill level, it is possible to switch the pump on and off automatically, by using the float switch.

Plug

In the "E" version, a shockproof plug is attached and the "D" version has a CEE plug. The plug is designed for use in commercially available shock-proof or CEE sockets and is **not** overflow-proof.

4.2 Monitoring devices

Overview of monitoring devices:

	KS...	KS...Ex
Motor compartment	-	•
Motor winding	-	•
Motor bearings	-	-
Sealing chamber		
Internal electrode	-	-
External electrode	o	o

Key: - = not available/possible, o = optional, • = as standard

All the monitoring devices fitted must always be connected!

Monitoring of motor winding

The thermal motor monitoring protects the motor winding from overheating. Temperature limiter with bimetallic strip is fitted as standard.

Sealing chamber monitoring

The sealing chamber can be equipped with an external pencil electrode. The electrode registers fluid ingress through the mechanical seal on the fluid side. An alarm or deactivation of the pump can therefore take place through pump control.

4.3 Operating modes

Operating mode S1: Continuous duty

The pump can operate continuously at the rated load without exceeding the permissible temperature.

Operating mode: Non-immersed operation

The “non-immersed operation” operating mode describes the possibility of the motor emerging during the drainage pumping sequence. This allows a further lowering of the water level as far as the upper edge of the hydraulics. Observe the following points during non-immersed operation:

- Operating mode
KS...: The motor can be run non-immersed in continuous duty (S1).
KS... Ex: The motor emerging in “non-immersed” operating mode is permissible.
DANGER! Risk of explosion due to motor overheating! The motor must not emerge in explosive atmospheres!
- Max. fluid and ambient temperature: The max. ambient temperature corresponds to the max. fluid temperature shown on the rating plate.

“Slurping operation” operating mode

Slurping operation facilitates the pumping of very small amounts of fluid. This operating mode corresponds to a dry run. **DANGER! Risk of explosion due to motor overheating! Slurping operation is strictly forbidden in explosive atmospheres!**

4.4 Operation with frequency converter

Operation on the frequency converter is not permitted.

4.5 Operation in an explosive atmosphere

Type	Approval according to		
	ATEX	FM	CSA
KS 5 Ex	•	•	–
KS 6 Ex	•	•	–
KS 8	–	–	–
KS 9	–	–	–
KS 12	–	–	–
KS 14	–	–	–
KS 15	–	–	–
KS 16 Ex	•	•	–
KS 20	–	–	–
KS 24	–	–	–
KS 37	–	–	–
KS 70	–	–	–

Key: – = not available/possible, • = as standard

For use in explosive atmospheres, the pump must be marked as follows on the rating plate:

- “Ex” symbol of the corresponding approval
- Ex classification

For the relevant requirements, refer to the explosion protection chapter in the appendix of these installation and operating instructions!

ATEX approval

The pumps are suitable for operation in potentially explosive atmospheres:

- Device group: II
- Category: 2, zone 1 and zone 2

These pumps must not be used in zone 0!

FM approval

The pumps are suitable for operation in potentially explosive atmospheres:

- Protection class: Explosionproof
- Category: Class 1, Division 1 and Division 2

4.6 Technical data

General	
Mains connection [U/f]	See rating plate
Rated power [P ₂]	See rating plate

Max. delivery head [H]	See rating plate
Max. volume flow [Q]	See rating plate
Fluid temperature [t]	3...40 °C
Protection class	IP68
Insulation class [Cl.]	F
Max. switching frequency	15/h
Max. immersion depth [Σ]	12.5 m
Weight (net)	See rating plate

Explosion protection

KS...	–
KS... Ex	ATEX, FM

Operating modes

Immersed [OTs]	S1
Non-immersed [OTe]	
– KS...:	S1
– KS... Ex:	S2-15
Slurping operation	
– KS...:	S1
– KS... Ex:	–

Pressure connection

KS 5 ... KS 9	Storz C (G 1¼)
KS 12 ... KS 16	Storz C (G 2)
KS 20	Storz B (G 2½)
KS 24	Storz B (G 3)
KS 37/KS 70	Storz A (G 4)

4.7 Type key

Example: Wilo-EMU KS 70ZN x¹ x² Ex

KS	Series
70	Size
Z	Pressure connection position without = lateral pressure connection Z = central pressure connection
N	Impeller version: without = standard impeller N = low-pressure impeller M = medium-pressure impeller H = high-pressure impeller
x ¹	Electric version: E = 1~ with shockproof plug E0 = 1~ bare cable end D = 3~ with CEE plug D0 = 3~ with bare cable end S = with float switch DMS = with float switch and CEE plug
x ²	Material version: without = standard version GG = cast iron version Ceram = with Ceram coating
Ex	Ex-rated

4.8 Scope of delivery

- Pump with 10 m (33 ft) or 20 m (66 ft) cable
- Storz coupling
- 90° bend
(for units with horizontal pressure connection)
- Connection cable with
 - Bare cable end

- Plug
 - Float switch and plug
 - Installation and operating instructions
- 4.9 Accessories**
- Cable lengths up to 50 metres (164 ft)
 - Pressure hoses
 - Storz hose couplings

5 Transportation and storage

5.1 Delivery

After receiving the shipment, this must be checked immediately for defects (damage, completeness). Defects must be noted on the freight documentation! Furthermore, defects must be notified to the transport company or the manufacturer immediately on the day of receipt of shipment. Subsequently notified defects can no longer be asserted.

5.2 Transport



WARNING

Standing under suspended loads!

Never allow anyone to stand under suspended loads! Danger of (serious) injuries caused by falling parts. Loads may not be carried over work places where people are present!



WARNING

Head and foot injuries due to a lack of protective equipment!

Danger of (serious) injuries during work. Wear the following protective equipment:

- Safety shoes
- Safety helmet must be worn if lifting equipment are used!



NOTICE

Only use lifting equipment in a technically sound condition!

Only use lifting equipment in a technically sound condition for lifting, lowering and transporting the pump. Ensure that the pump does not become jammed during lifting and lowering. Do **not** exceed the max. permissible bearing capacity of the lifting equipment!

CAUTION

Soaked packaging may tear!

The product may fall on the ground if unprotected and may be damaged. Lift wet packaging carefully and replace it immediately!

Only remove the outer packaging at the place of utilisation to ensure that the pump is not damaged during transport. Use tear-proof plastic sacks of sufficient size to package used pumps for transport in a leak-proof manner.

The following points must also be observed:

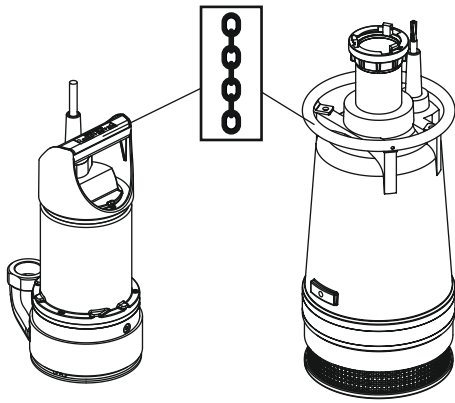

Fig. 2: Attachment point

5.3 Storage

- Adhere to the applicable national safety regulations.
- Use legally specified and approved lifting gear.
- Select the lifting gear based on the existing conditions (weather, attachment point, load, etc.).
- Only attach the lifting gear to the attachment point. Fix with a shackle.
- Use lifting equipment with sufficient bearing capacity.
- The stability of the lifting equipment must be ensured during operation.
- When using lifting equipment, a second person must be present to coordinate the procedure if required (e.g. if the operator's field of vision is blocked).



WARNING

Sharp edges on the impeller and suction port!

Sharp edges can form on the impeller and suction port. There is danger of limbs being severed! Protective gloves must be worn to protect from cuts.

CAUTION

Total damage due to moisture ingress

Moisture ingress in the power supply cable damages the power supply cable and the pump! Never immerse the end of the power supply cable in a fluid and firmly seal it during storage.

Newly supplied pumps can be stored for one year. Contact customer service to store the pump for more than one year.

The following must be observed for storage:

- Place the pump upright (vertical) on a firm bearing surface and **secure it against slipping and falling over!**
- The max. storage temperature is -15 °C to $+60\text{ °C}$ (5 °F to 140 °F) at a max. relative humidity of 90 %, non-condensing. Frost-proof storage at a temperature of 5 °C to 25 °C (41 °F to 77 °F) with relative humidity of 40 % to 50 % is recommended.
- Do not store the pump in rooms in which welding work is carried out. The resulting gases or radiation can corrode the elastomer parts and coatings.
- Seal the suction and pressure connection tightly.
- Protect power supply cables against kinking and damage.
- Protect the pump from direct sunlight and heat. Extreme heat can cause damage to the impellers and the coating!
- Impellers must be turned by 180 ° at regular intervals (3 – 6 months). This prevents locking of the bearings and renews the lubrication film of the mechanical seal. **WARNING! There is a risk of injury due to sharp edges on the impeller and suction port!**
- Elastomer parts and the coating are subject to natural brittleness. Contact customer service if the pump must be stored for more than 6 months.

After storage, remove any dust and oil from the pump and check the coating for damage. Repair damaged coatings before further use.

6 Installation and electrical connection

6.1 Personnel qualifications

- Electrical work: A qualified electrician must carry out the electrical work.
- Installation/dismantling: The technician must be trained in the use of the necessary tools and fixation materials for the relevant construction site.

6.2 Installation types

- Vertical portable wet well installation

The following installation types are **not** permitted:

- Vertical stationary wet well installation with suspension unit

6.3 Operator responsibilities

- Vertical stationary dry well installation
- Horizontal installation
- Observe locally applicable accident prevention and safety regulations of trade associations.
- Observe all regulations for working with heavy loads and under suspended loads.
- Provide protective equipment and ensure that the protective equipment is worn by personnel.
- Observe local sewage technology regulations for the operation of sewage systems.
- Avoid pressure surges!
Pressure surges can occur in long pressure pipes with steep terrain. These pressure surges can lead to the destruction of the pump!
- Ensure the cooling time of the motor depending on the operating conditions and the size of the pump chamber.
- Structural components and foundations must be of sufficient stability in order to allow the device to be fixed securely and functionally. The operator is responsible for the provision and suitability of the structural component/foundation!
- Check that the available consulting documents (installation plans, design of the operating space, inflow conditions) are complete and correct.

6.4 Installation



DANGER

Risk of fatal injury due to dangerous lone working practices!

Work in chambers and narrow rooms as well as work involving risk of falling are dangerous work. Such work may not be carried out autonomously! A second person must be present for safety reasons.



WARNING

Hand and foot injuries due to lack of protective equipment!

Danger of (serious) injuries during work. Wear the following protective equipment:

- Safety gloves for protection against cuts
- Safety shoes
- Safety helmet must be worn if lifting equipment are used!



NOTICE

Only use lifting equipment in a technically sound condition!

Only use lifting equipment in a technically sound condition for lifting, lowering and transporting the pump. Ensure that the pump does not become jammed during lifting and lowering. Do **not** exceed the max. permissible bearing capacity of the lifting equipment!

- Prepare operating space/installation location as follows:
 - Clean, free of coarse solids
 - Dry
 - Frost-free
 - Decontaminated
- Take immediate countermeasures if there is a build-up of toxic or suffocating gases!
- Use the handle for lifting, lowering and transporting the pump. Never carry or drag the pump by the power supply cable!
- It must be possible to attach lifting equipment safely. The storage place and the operating space/installation site must be accessible with the lifting equipment. The set-down location must have a solid bearing surface.
- Attach the lifting gear to the handle using a shackle. Only use lifting gear which has been technically approved.
- The routed power supply cables must allow safe operation. Check whether the cable cross-section and the cable length are sufficient for the selected installation type.
- The corresponding IP class must be observed when using switchgear. Install the switchgear in an overflow-proof position and away from potentially explosive areas!
- Avoid air intake into the fluid, use baffles or deflector plates for the inlet. Air which has entered the system can collect in the pipe system and lead to impermissible operating conditions. Air pockets must be removed via ventilation systems!

6.4.1 Maintenance tasks

6.4.1.1 Rotate impeller

After a storage period of more than 6 months, turn the impeller prior to installation.



WARNING

Sharp edges on the impeller and suction port!

Sharp edges can form on the impeller and suction port. There is danger of limbs being severed! Protective gloves must be worn to protect from cuts.

- ✓ The pump is **not** connected to the mains!
 - ✓ Protective equipment has been put on!
1. Place the pump upright on a firm surface.
WARNING! Risk of hands being crushed. Make sure that the pump cannot fall over or slip!
NOTICE! Do not position the pump horizontally, as otherwise oil can escape from the motor!
 2. Pumps **without** suction strainer: Reach into the hydraulics housing carefully from below and slowly and turn the impeller.
Pump with suction strainer: Insert a suitable tool through the suction strainer and turn the impeller.

6.4.2 Portable wet well installation



WARNING

Risk of burns from hot surfaces!

Motor housing can become hot during operation. It may cause burns. Allow the pump to cool down at ambient temperature after switching it off!



WARNING

Separation of pressure hose!

Separation or movement of the pressure hose can lead to (serious) injuries. Securely attach the pressure hose to the outlet! Prevent buckling of the pressure hose.

For portable installation, the pump is equipped with a strainer. The strainer filters coarse solids out of the fluid and enables secure standing if placed on a solid load bearing surface. This allows the pump to be installed anywhere in the operating space/installation location. To prevent sinking in, a hard base must be used at the installation location in case of soft load bearing surfaces. A pressure hose or pipework is connected on the pressure side.

Work steps

1	Pressure hose
2	Storz coupling (pressure hose)
3	Storz coupling (pressure connection)
4	Suction strainer
5	Pump
6	Handle: Attachment point for lifting equipment
7	Connection cable
8	Slurping operation

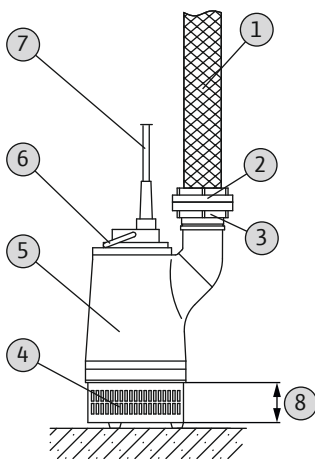

Fig. 3: Wet well installation, portable

- ✓ Pressure connection prepared: Hose connection or Storz coupling fitted.
1. Use a shackle to attach the hoisting gear to the attachment point of the pump.
 2. Lift and align the pump at the installation location.
 3. Place the pump on a solid load bearing surface. **CAUTION! Prevent the pump sinking in!**
 4. Lay the pressure hose and fasten it to a certain point (e.g. drainage). **DANGER! Separation or movement of the pressure hose can lead to (serious) injuries! Secure the pressure hose at the outlet.**
 5. Lay the connection cable properly. **CAUTION! Do not damage the connection cable!**
 - ▶ The pump is installed, the qualified electrician can make the electrical connection.

6.4.3 Level control

With a level control device, the current fill levels are determined and the pump is switched on and off automatically depending on the fill levels. Fill levels are recorded by using different sensor types (float switches, pressure and ultrasound measurements or electrodes). The following must be observed when using a level control device:

- Float switches can move freely!
- The water level must **not fall below** the minimum permissible!
- The maximum switching frequency **must not be exceeded!**
- If the fill levels fluctuate strongly, a level control with two measuring points is recommended. This makes it possible to achieve larger differential gaps.

Use of attached float switch

The "S" version is equipped with a float switch. The pump is switched on and off depending on the fill level. The switching level is determined by the cable length of the float switch.

Use of on-site level controls

When using an on-site level control device, refer to the manufacturer's own installation and operating instructions for specifications on the installation.

6.5 Electrical connection



DANGER

Risk of death due to electrocution!

Improper conduct when carrying out electrical work can lead to death due to electric shock! Electrical work must be carried out by a qualified electrician in accordance with the locally applicable regulations.



DANGER

Risk of explosion due to incorrect connection!

- Always connect the pump to an electrical outlet outside the explosive area. If the connection must be made within the explosive area, then connection must be carried out in an Ex-rated housing (ignition protection class DIN EN 60079-0)! Non-observance may lead to fatal injury due to explosion!
- Connect the potential compensator to the earth terminal indicated. The earth terminal is installed in the area of the power supply cable. A cable cross-section in accordance with the locally applicable regulations must be used for the potential compensator.
- Connection must always be carried out by a qualified electrician.
- For the electrical connection, also note the additional information in the chapter on potentially explosive areas found in the appendix of these installation and operating instructions!

- The mains connection must match the specifications on the rating plate.
- Power supply on mains side for three-phase current motors with clockwise rotating field.
- Lay the power supply cables in accordance with the locally applicable regulations and connect them according to the wire assignment.
- Connect the monitoring devices and check their function.
- Earth the device properly in accordance with applicable local regulations.

6.5.1 Fuse on mains side

Circuit breaker

The size of the circuit breakers conforms to the rated current of the pump. The switching characteristics should comply with group B or C. Observe local regulations.

Motor protection switch

Make provision for an on-site motor protection switch for devices without a plug! The minimum requirement is a thermal relay/motor protection switch with temperature compensation, differential triggering and anti-reactivation device in accordance with the local regulations. In case of sensitive mains, make provision for the installation on-site of other protective equipment (e.g. overvoltage, undervoltage or phase failure relay, etc.).

Residual-current device (RCD)

Comply with the regulations of the local energy supply company! The use of a residual-current device is recommended.

If persons come into contact with the device and conductive fluids, secure the connection **with** a residual-current device (RCD).

6.5.2 Maintenance tasks

Carry out the following maintenance tasks prior to installation:

- Check the insulation resistance of the motor winding.
- KS...Ex only: Test the resistance of the temperature sensor.
- Test the resistor of the pencil electrode (optionally available).

If the measured values differ from the specifications, moisture may have penetrated into the motor or the power supply cable or the monitoring device is defective. Contact customer service in the event of a fault.

6.5.2.1 Checking the insulation resistance of the motor winding

Use an insulation tester to measure the insulation resistance (measuring voltage = 1000 V). Observe the following values:

- At the time of initial commissioning: Insulation resistance may not be less than 20 MΩ.
- For further measurements: Value must be greater than 2 MΩ.

6.5.2.2 Test the resistor of the temperature sensor

Measure the resistor of the temperature sensors with an ohmmeter. The following measured values must be complied with:

- **Bimetallic strip:** Measured value = 0 Ohm (passage).
- **PTC sensor** (PTC thermistor): Measured value depends on the number of sensors installed. At PTC sensor has a cold resistance of between 20 and 100 Ohm.
 - With **three** sensors in series, the measured value is between 60 und 300 Ohm.
 - With **four** sensors in series, the measured value is between 80 und 400 Ohm.

6.5.2.3 Testing the resistor of the external electrode for sealing chamber control

Measure the resistor of the electrode with an ohmmeter. The measured value must approach "infinity". For values ≤ 30 kOhm, if there is water in the oil – change the oil!

6.5.3 Connection of the single-phase current motor

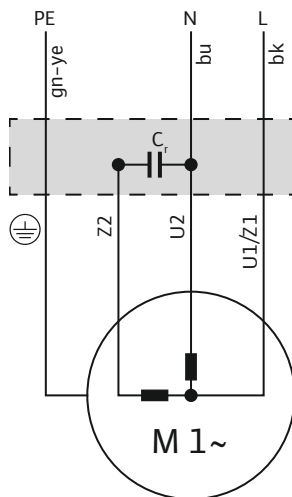

Fig. 4: Connection diagram single-phase current motor

Wire colour	Terminal
Black (bk)	L
Blue (bu)	N
Green/yellow (gn-ye)	Earth

The single-phase current version is equipped with a shockproof plug. The connection to the mains is established by inserting the plug into a socket. The plug is **not** overflow-proof. **Install the socket so that it is overflow-proof!** Observe the information on the protection class (IP) of the plug.

DANGER! If the pump is connected directly to the switchgear, dismantle the plug and arrange for the electrical connection to be carried out by a qualified electrician!

6.5.4 Three-phase current motor connection

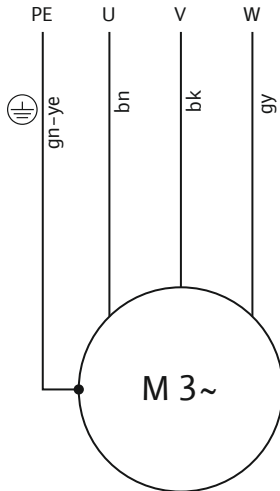

Fig. 5: Connection diagram three-phase current motor EMU KS...

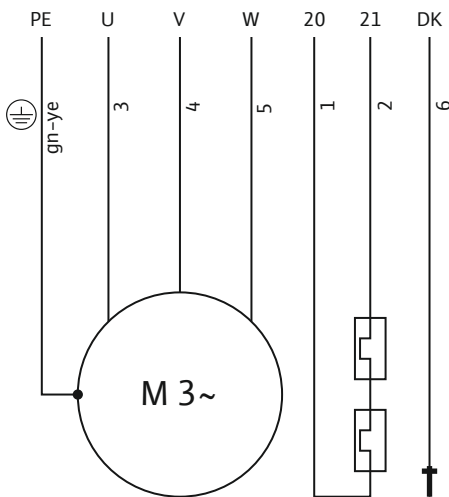

Fig. 6: Connection diagram three-phase current motor EMU KS...Ex

6.5.5 Monitoring equipment connection

EMU KS...

Wire colour	Designation	Terminal
Brown (bn)	U	L1
Black (bk)	V	L2
Grey (gy)	W	L3
Green/yellow (gn-ye)	Earth	PE

For three-phase current motors, a clockwise rotating field must be available. The three-phase current version is equipped with a CEE plug or with a bare cable end:

- If a CEE plug is supplied, connection to the mains is established by inserting the plug into a socket. The plug is **not** overflow-proof. **Install the socket so that it is overflow-proof!** Observe the information on the protection class (IP) of the plug.
- If there is a bare cable-end, the pump must be connected directly to the switchgear. **DANGER! If the pump is connected directly to the switchgear, arrange for the electrical connection to be carried out by a qualified electrician!**

EMU KS...Ex

Wire	Designation	Terminal
1, 2	20, 21	Monitoring of motor winding
3	U	L1
4	V	L2
5	W	L3
6	DK	Monitoring of motor compartment
Green/yellow (gn-ye)	PE	Earth

The three-phase current version is equipped with bare cable ends. Connection to the mains is established by connecting the power supply cable in the switchgear. **Electrical connection must always be carried out by a qualified electrician!**

For the correct direction of rotation, a clockwise rotating field must be available.

NOTICE! The individual wires are designated according to the connection diagram. Do not cut the wires! There is no additional assignment between the wiring diagram and connection diagram.

Refer to the enclosed connection diagram for details regarding the connection and installation of the monitoring devices. **Electrical connection must always be carried out by a qualified electrician!**

NOTICE! The individual wires are designated according to the connection diagram. Do not cut the wires! There is no additional assignment between the wiring diagram and connection diagram.



DANGER

Risk of explosion due to incorrect connection!

If the monitoring devices are not connected correctly, there is a risk of fatal injury due to explosion in potentially explosive areas! Connection must always be carried out by a qualified electrician. If used in potentially explosive areas:

- Connect the thermal motor monitoring via an evaluation relay!
- Deactivation by the temperature limiter must be conducted with re-activation lock! It must only be possible to restart the unit when the unlock key has been actuated by hand!
- Connect the external electrode (e.g. sealing chamber control) via an evaluation relay with an intrinsically safe circuit!
- Note the additional information in the chapter on potentially explosive areas found in the appendix of these installation and operating instructions!

Overview of monitoring devices:

	KS...	KS...Ex
Motor compartment	-	•
Motor winding	-	•
Motor bearings	-	-
Sealing chamber		
Internal electrode	-	-
External electrode	o	o

Key: - = not available/possible, o = optional, • = as standard

All the monitoring devices fitted must always be connected!

6.5.5.1 Monitoring of motor winding (KS...Ex only)

With bimetallic strip

Connect the bimetallic strips in the switchgear itself or via an evaluation relay. Connection values: max. 250 V(AC), 2.5 A, $\cos \varphi = 1$

Wiring diagram for bimetallic strip

Temperature limiter

20 Bimetallic strip connection

21

Temperature control

21 High temperature connection

20 Centre terminal

22 Low temperature connection

With PTC sensor

Connect the PTC sensor via an evaluation relay. Relay "CM-MSS" is recommended for this. The threshold is preset.

PTC sensor wiring diagram

Temperature limiter

10 PTC sensor connection

11

Temperature control

11 High temperature connection

10 Centre terminal

12 Low temperature connection

Triggering status with temperature control and limiting

Depending on the version of the thermal motor monitoring, the following triggering status must occur when the threshold value is reached:

- Temperature limiting (1 temperature circuit):
When the threshold is reached, deactivation must take place.
 - Temperature control (2 temperature circuits):
When the threshold for the low temperature is reached, the motor can deactivate with automatic reactivation. When the threshold for the high temperature limit is reached, the motor must deactivate with manual reactivation.
- Note the additional information in the chapter on potentially explosive areas found in the appendix!**
- 6.5.5.2 Sealing chamber monitoring (external electrode)** Connect the external electrode via an evaluation relay. Relay "NIV 101/A" is recommended for this. The threshold is 30 kOhm.
- When the threshold is reached, a warning must be given or the unit must be switched off.**

CAUTION

Connection of the sealing chamber control

If on reaching the threshold, there is only a warning, the pump could be irreparably damaged by the water ingress. Deactivation of the pump is always recommended!

Note the additional information in the chapter on potentially explosive areas found in the appendix!

- 6.5.6 Motor protection adjustment**
- 6.5.6.1 Direct activation** Motor protection must be set depending on the selected activation type.
At full load, set the motor protection switch to the rated current (see rating plate). At partial load, it is recommended to set the motor protection switch 5 % above the current measured at the duty point.
- 6.5.7 Operation with frequency converter** Operation on the frequency converter is not permitted.

7 Commissioning



WARNING

Foot injuries due to a lack of protective equipment!

Danger of (serious) injuries during work. Wear safety shoes!

- 7.1 Personnel qualifications**
- Electrical work: A qualified electrician must carry out the electrical work.
 - Operation/control: Operating personnel must be instructed in the functioning of the complete system.
- 7.2 Operator responsibilities**
- Providing installation and operating instructions by the pump or at a place specially reserved for it.
 - Making the installation and operating instructions available in the language of the personnel.
 - Making sure that the installation and operating instructions are read and understood by all personnel.
 - All safety devices and emergency cut-outs on the system-side must be active and checked to ensure that they work properly.
 - The pump is suitable for use under the specified operating conditions.
- 7.3 Direction of rotation check (for three-phase current motors only)** The pump is factory-checked and adjusted to the correct direction of rotation for a clockwise rotating field. Connection is made in accordance with the specifications in chapter "Electrical connection".

Direction of rotation check

A qualified electrician checks the rotating field at the mains connection with a rotating field-test device. For the correct direction of rotation, a clockwise rotating field must be available at the mains connection. The pump is **not** approved for operation with a counter-clockwise rotating field! **CAUTION! If the direction of rotation is checked with a test run, comply with the ambient and operating conditions!**

Incorrect direction of rotation

If the direction of rotation is false, change the connection as follows:

- Swap two phases for motors with direct starting.
- Swap the connections of two windings (e.g. U1/V1 and U2/V2) for star-delta activation motors.

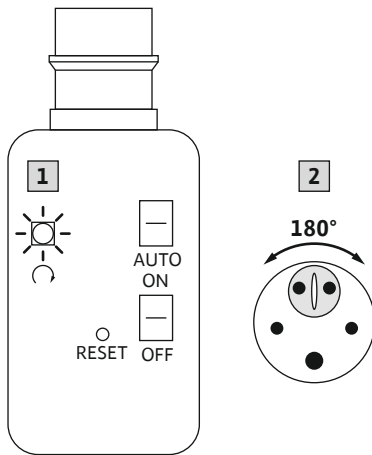

Fig. 7: Phase inverter

Pumps with CEE plug and phase inverter

1. Insert CEE plug into the socket.
2. Check the control lamp.
 - ⇒ Control lamp off: Direction of rotation ok.
 - ⇒ Control lamp on: Incorrect direction of rotation.
3. Correct the direction of rotation.
 - ⇒ Use a suitable screwdriver to press in the phase inverter in the plug and turn by 180°.
 - ▶ Direction of rotation set correctly.

7.4 Operation in an explosive atmosphere



DANGER

Risk of explosion due to flying sparks in the hydraulics!

During operation the hydraulics must be flooded (completely filled with the fluid). If the volume flow is interrupted or the hydraulics emerges, air cushions can form in the hydraulics. If this happens, there is a risk of explosion, e.g. flying sparks due to static charge! Dry-running protection must ensure that the pump is deactivated at the appropriate level.

Type	Approval according to		
	ATEX	FM	CSA
KS 5 Ex	•	•	–
KS 6 Ex	•	•	–
KS 8	–	–	–
KS 9	–	–	–
KS 12	–	–	–
KS 14	–	–	–
KS 15	–	–	–
KS 16 Ex	•	•	–
KS 20	–	–	–
KS 24	–	–	–
KS 37	–	–	–
KS 70	–	–	–

Key: – = not available/possible, • = as standard

For use in explosive atmospheres, the pump must be marked as follows on the rating plate:

- “Ex” symbol of the corresponding approval
- Ex classification

For the relevant requirements, refer to the explosion protection chapter in the appendix of these installation and operating instructions!

ATEX approval

The pumps are suitable for operation in potentially explosive areas, which require devices belonging to group II, category 2. The pumps can be used in both zone 1 and zone 2.

These pumps must not be used in zone 0!

FM approval

The pumps are suitable for operation in potentially explosive areas, which require devices belonging to the protection class “Explosion proof, Class 1, Division 1”. Therefore, operation in areas with the required protection class “Explosion proof, Class 1, Division 2” is also possible.

7.5 Before switching on

Check the following prior to activation:

- Check whether the device has been installed properly and in accordance with the locally applicable regulations:
 - Has the pump been earthed?
 - Power supply cable routing tested?
 - Electrical connection made according to the regulations?
 - Mechanical components attached correctly?
- Check level control:
 - Float switches can move freely?
 - Switching level tested (pump on, pump off, minimum water level)?
 - Additional dry-running protection installed?
- Test operating conditions:
 - Min./max. temperature of the fluid tested?
 - Max. immersion depth tested?
 - Operating mode defined depending on the minimum water level?
 - Maximum switching frequency adhered to?
- Check installation location/operating space:
 - Pipe system on the pressure side free of deposits?
 - Inlet or pump sump cleaned or free of deposits?
 - All gate valves open?

7.6 Switching on and off

During the start process, the rated current is temporarily exceeded. During operation, the rated current may no longer be exceeded. **CAUTION! If the pump does not start, switch off the pump immediately. Remove the fault before reactivating the pump!**

Pumps with bare cable end

The pump must be switched on and off using a separate operating point (on/off switch, switchgear) provided by the customer.

Pump with attached plug

- After inserting the plug into the socket, the pump is ready for operation. The pump is switched on and off with the ON/OFF switch.

Pump with attached float switch and plug

- After inserting the plug into the socket, the pump is ready for operation. The pump is controlled via two switches on the plug:
 - HAND/AUTO: Determines if the pump is switched on and off directly (HAND) or depending on the fill level (AUTO).
 - ON/OFF: Switches the pump on and off.

7.7 During operation



WARNING

Amputation of limbs due to rotating components!

No persons must be present in the work area of the pump! There is risk of (serious) injuries due to rotating components! No persons must be present in the work area of the pump during start-up or operation.



WARNING

Risk of burns from hot surfaces!

Motor housing can become hot during operation. It may cause burns. Allow the pump to cool down at ambient temperature after switching it off!

When operating the pump, observe the locally applicable regulations on the following topics:

- Work safety
- Accident prevention
- Handling electrical machines

Strictly adhere to the responsibilities of the personnel specified by the operator. All personnel are responsible for ensuring that the responsibilities of the personnel and the regulations are observed!

Due to their design, centrifugal pumps have rotating parts that are easily accessible. Depending on the operating condition, sharp edges can develop on these parts. **WARNING! This can lead to cuts and limbs may be severed!** Check the following at regular intervals:

- Operating voltage (+/-10 % of the rated voltage)
- Frequency (+/-2 % of the rated frequency)
- Power consumption between individual phases (max. 5 %)
- Voltage difference between the individual phases (max. 1 %)
- Max. switching frequency
- Minimum water submersion depending on the operating mode
- Inlet: no air intake
- Level control device/dry-running protection: Switching points
- Quiet/low-vibration running
- All gate valves open

8 Shut-down/dismantling

8.1 Personnel qualifications

- Operation/control: Operating personnel must be instructed in the functioning of the complete system.
- Electrical work: A qualified electrician must carry out the electrical work.
- Installation/dismantling: The technician must be trained in the use of the necessary tools and fixation materials for the relevant construction site.

8.2 Operator responsibilities

- Locally applicable accident prevention and safety regulations of trade associations.
- Observe regulations for working with heavy loads and under suspended loads.
- Provide the necessary protective equipment and make sure that the personnel wears it.
- Provide adequate aeration in closed rooms.
- Take immediate countermeasures if there is a build-up of toxic or suffocating gases!

8.3 Shut-down

The pump is deactivated during decommissioning, but remains installed. This ensures that the pump is always ready for operation.

- ✓ To protect the pump from frost and ice, always immerse the pump completely in the fluid.
 - ✓ The temperature of the fluid must always be above +3 °C (+37 °F).
1. Switch off the pump at the operating point.
 2. Secure the operating point against being switched on again by unauthorised persons (e.g. lock main switch).
 - ▶ The pump is out of operation and can now be dismantled.

If the pump remains installed after decommissioning, observe the following:

- Ensure that the prerequisites for decommissioning are maintained for the complete period of decommissioning. If these prerequisites cannot be guaranteed, dismantle the pump after decommissioning!
- For an extended period of decommissioning, carry out a 5-minute function test at regular intervals (monthly to quarterly). **CAUTION! A function test may only be carried out under the applicable operating conditions. A dry run is not permitted! Non-compliance can result in irreparable damage!**

8.4 Removal



DANGER

Danger due to fluids hazardous to health!

If the pump is used in fluids hazardous to health, decontaminate the pump after dismantling and before carrying out any other work! There is a risk of fatal injury! Observe the specifications in the work regulations! The operator must make sure that the personnel have received and read the work regulations!



DANGER

Risk of death due to electrocution!

Improper conduct when carrying out electrical work can lead to death due to electric shock! Electrical work must be carried out by a qualified electrician in accordance with the locally applicable regulations.



DANGER

Risk of fatal injury due to dangerous lone working practices!

Work in chambers and narrow rooms as well as work involving risk of falling are dangerous work. Such work may not be carried out autonomously! A second person must be present for safety reasons.



WARNING

Risk of burns from hot surfaces!

Motor housing can become hot during operation. It may cause burns. Allow the pump to cool down at ambient temperature after switching it off!

NOTICE

Only use lifting equipment in a technically sound condition!

Only use lifting equipment in a technically sound condition for lifting, lowering and transporting the pump. Ensure that the pump does not become jammed during lifting and lowering. Do **not** exceed the max. permissible bearing capacity of the lifting equipment!

8.4.1 Portable wet well installation

- ✓ Pump is taken out of operation.
- 1. Disconnect the pump from the mains.
- 2. Roll up the power supply cable and place it over the motor housing. **CAUTION! Never pull on the power supply cable! This damages the power supply cable!**
- 3. Loosen the pressure pipe from the pressure port.
- 4. Attach the lifting equipment to the attachment point.
- 5. Lift the pump from the operating space. **CAUTION! The power supply cable may be squeezed and damaged when setting the pump down! Pay attention to the power supply cable when setting the pump down!**
- 6. Clean the pump thoroughly (see point "Cleaning and disinfecting"). **DANGER! Disinfect the pump when used in fluids hazardous to health!**

8.4.2 Clean and disinfect



DANGER

Danger due to fluids hazardous to health!

Danger to life if the pump is used in fluids hazardous to health! Decontaminate the pump before carrying out any further work! Wear the following protective equipment while performing cleaning tasks:

- Closed safety goggles
- Breathing mask
- Protective gloves
 - The equipment listed here is the minimum requirement, observe the specifications of the work regulations! The operator must make sure that the personnel have received and read the work regulations!

- ✓ Pump is dismantled.
- ✓ The contaminated cleaning water is disposed of in the sewage in accordance with the locally applicable regulations.
- ✓ A disinfectant is provided for contaminated pumps.
- 1. Attach the lifting equipment to the attachment point of the pump.
- 2. Lift the pump approximately 30 cm above the ground.
- 3. Spray the pump with clear water from top to bottom. **NOTICE! An appropriate disinfectant must be used for contaminated pumps! Strictly observe the manufacturer's specifications concerning use!**
- 4. To clean the impeller and the interior pump space, guide the water jet inside via the pressure port.

5. Flush all dirt residue onto the floor of the channel.
6. Allow the pump to dry out.

9 Maintenance and repair



DANGER

Danger due to fluids hazardous to health!

If the pump is used in fluids hazardous to health, decontaminate the pump after dismantling and before carrying out any other work! There is a risk of fatal injury! Observe the specifications in the work regulations! The operator must make sure that the personnel have received and read the work regulations!

NOTICE

Only use lifting equipment in a technically sound condition!

Only use lifting equipment in a technically sound condition for lifting, lowering and transporting the pump. Ensure that the pump does not become jammed during lifting and lowering. Do **not** exceed the max. permissible bearing capacity of the lifting equipment!

- Always carry out maintenance tasks in a clean location with good lighting. It must be possible to position the pump safely and secure it.
 - Only carry out maintenance tasks mentioned in these installation and operating instructions.
 - Wear the following protective equipment while performing maintenance tasks:
 - Safety goggles
 - Safety shoes
 - Safety gloves
- 9.1 Personnel qualifications**
- Electrical work: A qualified electrician must carry out the electrical work.
 - Maintenance tasks: The technician must be familiar with the use of operating fluids and their disposal. In addition, the technician must have basic knowledge of mechanical engineering.
- 9.2 Operator responsibilities**
- Provide the necessary protective equipment and make sure that the personnel wears it.
 - Collect operating fluids in suitable tanks and dispose of properly.
 - Dispose of protective clothing used in accordance with regulations.
 - Use only original parts of the manufacturer. Use of parts other than the original parts releases the manufacturer from any liability.
 - Collect any leakage of fluid and operating fluid immediately and dispose of it according to the locally applicable guidelines.
 - Provide the tools required.
 - If flammable solvents and cleaning agents are used, open flames, naked lights and smoking are prohibited.

9.3 Operating fluid

9.3.1 Oil types

Biological white oil is added to the motor and the sealing chamber. The following oil types are recommended when changing the oil:

- Aral Autin PL*
- Shell ONDINA 919
- Esso MARCOL 52* or 82*
- BP WHITEMORE WOM 14*
- Texaco Pharmaceutical 30* or 40*

All oil types marked with "*" are approved for use with foods in accordance with "USDA-H1".

9.3.2 Filling quantities

Type	Sealing chamber	Motor
KS 8, KS 9, KS 14	200 ml (6.8 US.fl.oz.)	900 ml (30.4 US.fl.oz.)
KS 12, KS 15	140 ml (4.7 US.fl.oz.)	820 ml (27.7 US.fl.oz.)
KS 20	400 ml (13.5 US.fl.oz.)	1300 ml (44 US.fl.oz.)
KS 24	350 ml (11.8 US.fl.oz.)	1350 ml (45.6 US.fl.oz.)
KS 37, KS 70	1400 ml (47.3 US.fl.oz.)	3000 ml (101.4 US.fl.oz.)

Type	Sealing chamber	Motor
KS...Ex	550 ml (18.6 US.fl.oz.)	-

9.4 Maintenance intervals

To ensure reliable operation, maintenance tasks must be carried out regularly. Depending on the real ambient temperatures, maintenance intervals different from those mentioned in the contract can be defined! If strong vibrations occur during operation, the pump and the installation must be checked regardless of the defined maintenance intervals.

9.4.1 Maintenance intervals for normal conditions

2 years

- Visual inspection of the power supply cable
- Visual inspection of accessories
- Visual inspection of the coating and housing for wear
- Function test of monitoring devices
- Oil change

NOTICE! If a sealing chamber control is installed, the oil is changed according to the indicator!

15000 operating hours or after 10 years at the latest

- General overhaul

9.4.2 Maintenance intervals for harsh conditions

Under harsh operating conditions, specified maintenance intervals must be shortened if required. Harsh operating conditions include:

- Fluids with long-fibre components
- Turbulent inlet (e.g. due to air intake, cavitation)
- Strongly corroding or abrasive fluids
- Heavily gas generating fluids
- Operation at an unfavourable duty point
- Pressure surges

When using pumps under hard conditions, it is recommended to sign a maintenance contract. Contact customer service.

9.5 Maintenance measures



WARNING

Sharp edges on the impeller and suction port!

Sharp edges can form on the impeller and suction port. There is danger of limbs being severed! Protective gloves must be worn to protect from cuts.



WARNING

Hand, foot or eye injuries due to the absence of protective equipment!

Danger of (serious) injuries during work. Wear the following protective equipment:

- Safety gloves for protection against cuts
- Safety shoes
- Closed safety goggles

The following pre-requisites must be fulfilled prior to starting maintenance measures:

- Pump cooled down to the ambient temperature.
- Pump cleaned thoroughly and disinfected (if required).

9.5.1 Visual inspection of the power supply cable

The power supply cables must be checked for:

- Bubbles
- Cracks
- Scratches
- Abrasion
- Crushing

If the power supply cables are damaged, the pump must be decommissioned immediately! Customer service must replace the damaged power supply cable. The pump may only be started up again once the damage has been properly remedied.

CAUTION! Water may penetrate into the pump due to the damaged power supply cables! Water ingress leads to total damage of the pump.

9.5.2 Visual inspection of accessories	Accessories must be checked for: <ul style="list-style-type: none"> • Correct fixation • Smooth function • Wear symptoms Any defects detected must be repaired immediately or the accessories must be replaced.
9.5.3 Visual inspection of coatings and housing for wear	The coatings and housing parts must not show any signs of damage. If there are defects, the following must be observed: <ul style="list-style-type: none"> • If the coating is damaged, it must be restored. • Contact customer service if housing parts have worn out!
9.5.4 Function test of the monitoring device	To test resistances, the pump must be cooled down to the ambient temperature!
9.5.4.1 Test the resistor of the internal electrodes for motor compartment monitoring	Measure the resistor of the electrode with an ohmmeter. The measured value must approach "infinity". For values ≤ 30 kOhm, there is water in the motor compartment. Contact customer service!
9.5.4.2 Test the resistor of the temperature sensor	Measure the resistor of the temperature sensors with an ohmmeter. The following measured values must be complied with: <ul style="list-style-type: none"> • Bimetallic strip: Measured value = 0 Ohm (passage). • PTC sensor (PTC thermistor): Measured value depends on the number of sensors installed. At PTC sensor has a cold resistance of between 20 and 100 Ohm. <ul style="list-style-type: none"> – With three sensors in series, the measured value is between 60 und 300 Ohm. – With four sensors in series, the measured value is between 80 und 400 Ohm.
9.5.4.3 Testing the resistor of the external electrode for sealing chamber control	Measure the resistor of the electrode with an ohmmeter. The measured value must approach "infinity". For values ≤ 30 kOhm, if there is water in the oil – change the oil!
9.5.5 Oil change	An oil change is recommended for these pumps after 2 years. Customer service carries out the oil change on-site.
9.5.6 General overhaul	During the general overhaul, the motor bearings, shaft sealings, O-rings and power supply cables are checked for wear and damage. Damaged components are replaced with original parts. This will ensure correct operation. The general overhaul is performed by the manufacturer or an authorised service centre.

10 Faults, causes and remedies



WARNING

Risk of injury from rotating components!

No persons are allowed to be present in the working area of the pump. There is a risk of injury!

- Demarcate and cordon off the working area.
- If there are no persons in the working area, activate the pump.
- If persons enter the working area, switch off the pump immediately.

Fault: Pump does not start

1. Electricity supply interrupted or short-circuit/earth fault in the cable or motor winding.
⇒ Have the connection and motor checked by a qualified electrician and replace if necessary.
2. Tripping of fuses, of the motor protection switch or the monitoring device
⇒ Have the connection and the monitoring device checked by a qualified electrician and change it if necessary.
⇒ Have the motor protection switches and fuses installed and adjusted according to the technical specifications by a qualified electrician and reset monitoring device.
⇒ Check the impeller to make sure that it runs smoothly, clean the hydraulics if necessary.
3. The sealing chamber control (optional) has interrupted the electric circuit (connection-related)
⇒ See "Fault: Mechanical seal leakage, sealing chamber control reports a fault and switches the pump off".

Fault: Pump starts up, motor protection trips after short period

1. Motor protection switch set incorrectly.
⇒ Have the adjustment of the trigger checked and corrected by a qualified electrician.

2. Increased power consumption due to major voltage drop.
⇒ Have the voltage of individual phases checked by a qualified electrician. Contact the electricity distribution network.
3. There are only two phases at the connection.
⇒ Have the connection checked and corrected by a qualified electrician.
4. Excessive differences in voltage between the phases.
⇒ Have the voltage of individual phases checked by a qualified electrician. Contact the electricity distribution network.
5. Incorrect direction of rotation.
⇒ Have the connection corrected by a qualified electrician.
6. Increased power consumption through jammed hydraulics.
⇒ Clean the hydraulics and check the inlet.
7. The density of the fluid is too high.
⇒ Contact customer service.

Fault: Pump runs, there is no volume flow

1. There is no fluid.
⇒ Check the inlet, open all gate valves.
2. Inlet clogged.
⇒ Check the inlet and remove clogging.
3. Hydraulics jammed.
⇒ Clean the hydraulics.
4. Pipe system on the pressure side or pressure hose clogged.
⇒ Remove clogging and replace the damaged components if necessary.
5. Intermittent operation.
⇒ Check the switching system.

Fault: Pump starts, duty point is not reached

1. Inlet clogged.
⇒ Check the inlet and remove clogging.
2. Slide valves on the pressure side closed.
⇒ Completely open all gate valves.
3. Hydraulics jammed.
⇒ Clean the hydraulics.
4. Incorrect direction of rotation.
⇒ Have the connection corrected by a qualified electrician.
5. Air cushion in the pipe system.
⇒ Vent the pipe system.
⇒ If air cushions occur frequently: Locate and prevent the air intake, if required install ventilation systems at specified locations.
6. Pump pumping against excessive pressure.
⇒ Open all gate valves on the pressure side completely.
7. Signs of wear on the hydraulics.
⇒ Have the components (impeller, suction port, pump housing) checked and replaced by customer service.
8. Pipe system on the pressure side or pressure hose clogged.
⇒ Remove clogging and replace the damaged components if necessary.
9. Strongly gassing fluid.
⇒ Contact customer service.
10. The connection only has two phases.
⇒ Have the connection checked and corrected by a qualified electrician.
11. Excessive decrease in the fill level during operation.
⇒ Check supply/capacity of the system.
⇒ Have the switching points of the level control checked and adjusted if necessary.

Fault: The pump does not run smoothly and is noisy

1. Improper duty point.
⇒ Check the pump configuration and the duty point, contact customer service.
2. Hydraulics jammed.
⇒ Clean the hydraulics.
3. Strongly gassing fluid.
⇒ Contact customer service.
4. There are only two phases at the connection.

- ⇒ Have the connection checked and corrected by a qualified electrician.
- 5. Incorrect direction of rotation.
 - ⇒ Have the connection corrected by a qualified electrician.
- 6. Signs of wear on the hydraulics.
 - ⇒ Have the components (impeller, suction port, pump housing) checked and replaced by customer service.
- 7. Motor bearings have worn.
 - ⇒ Inform customer service; send the pump back to the factory for overhauling.
- 8. Pump is installed under tension.
 - ⇒ Check installation, install rubber compensators if necessary.

Fault: Sealing chamber control reports fault or switches the pump off

1. Condensation water build-up due to extended storage or high temperature fluctuations.
 - ⇒ Operate the pump for a short period (max. 5 min.) without pencil electrode.
2. Increased leakage when running in new mechanical seals.
 - ⇒ Change the oil.
3. Pencil electrode cable is defective.
 - ⇒ Replace the pencil electrode.
4. Mechanical seal is defective.
 - ⇒ Inform customer service.

Further steps for troubleshooting

If the points listed here do not rectify the fault, contact customer service. Customer service can assist in the following ways:

- Telephone or written support.
- On-site support.
- Inspection and repair at the factory.

Costs may be incurred if you request customer services! Please contact customer services for more information.

11 Spare parts

Spare parts are ordered via customer service. To avoid return queries and incorrect orders, the serial or article number must always be supplied. **Subject to change without prior notice!**

12 Disposal

12.1 Oils and lubricants

Operating fluids must be collected in suitable containers and disposed of in accordance with the locally applicable guidelines. Wipe up drips immediately!

12.2 Protective clothing

Used protective clothing must be disposed off in accordance with the locally applicable guidelines.

12.3 Information on the collection of used electrical and electronic products

Proper disposal and appropriate recycling of this product avoids environmental damage and risks to personal health.



NOTICE

Disposal in domestic waste is prohibited!

In the European Union this symbol may be included on the product, the packaging or the accompanying documentation. It means that the electrical and electronic products in question must not be disposed of along with domestic waste.

Please note the following points to ensure proper handling, recycling and disposal of the used products in question:

- Hand over these products at designated, certified collection points only.
- Observe the locally applicable regulations!

Please consult your local municipality, the nearest waste disposal site, or the dealer who sold the product to you for information on proper disposal. Further recycling information at <http://www.wilo-recycling.com>.

Subject to change without prior notice!

13 Appendix

13.1 Ex rating

This section contains further information on the operation of the pump in an explosive atmosphere. All personnel must read this section. **This section applies only to Ex-rated pumps!**

13.1.1 Identification of Ex-rated pumps

For use in explosive atmospheres, the pump must be marked as follows on the rating plate:

- “Ex” symbol of the corresponding approval
- Ex classification
- Certification number (depending on the approval)

The certification number, if required by the approval, is printed on the rating plate.

13.1.2 Protection class “Flameproof enclosure” and “Explosion proof”

The motor must be equipped with at least one temperature limiter (1-circuit temperature monitoring). A temperature control (2 circuit temperature monitoring) is also possible.

13.1.3 Intended use



DANGER

Explosion due to pumping of explosive fluids!

Pumping of highly flammable and explosive fluids (gasoline, kerosene, etc.) in pure form is strictly prohibited. There is a risk of fatal injury due to explosion! The pumps are not designed for these fluids.

ATEX approval

The pumps are suitable for operation in potentially explosive areas, which require devices belonging to group II, category 2. The pumps can be used in both zone 1 and zone 2.

These pumps must not be used in zone 0!

FM approval

The pumps are suitable for operation in potentially explosive areas, which require devices belonging to the protection class “Explosion proof, Class 1, Division 1”. Therefore, operation in areas with the required protection class “Explosion proof, Class 1, Division 2” is also possible.

13.1.4 Electrical connection



DANGER

Risk of death due to electrocution!

Improper conduct when carrying out electrical work can lead to death due to electric shock! Electrical work must be carried out by a qualified electrician in accordance with the locally applicable regulations.

- Always connect the pump to an electrical outlet outside the explosive area. If the connection must be made within the explosive area, then the connection must be carried out in an Ex-rated housing (ignition protection class according to DIN EN 60079-0)! Non-observance may lead to fatal injury due to explosion! Connection must always be carried out by a qualified electrician.
- All monitoring devices outside the “spark-proof areas” must be connected via an intrinsically safe circuit (e.g. Ex-i relay XR-4...).
- The voltage tolerance may not be higher than max. $\pm 10\%$.

Overview of monitoring devices:

	KS...	KS...Ex
Motor compartment	-	•
Motor winding	-	•
Motor bearings	-	-
Sealing chamber		
Internal electrode	-	-
External electrode	o	o

Key: - = not available/possible, o = optional, • = as standard

All the monitoring devices fitted must always be connected!

13.1.4.1 Monitoring of motor compartment

The connection is made as described in the “Electrical connection” section.

13.1.4.2 Monitoring of motor winding



DANGER

Risk of explosion due to overheating of the motor!

If the temperature limiter is connected incorrectly, there is a risk of explosion due to overheating of the motor! Always connect the temperature limiter to a manual reactivation lock. This means that a “release button” must be manually activated!

The motor is equipped with a temperature limiter (1-circuit temperature monitoring).

When the threshold is reached, deactivation must occur with a **restart interlock!**

Connection of the thermal motor monitoring

- Connect the bimetallic strip via an evaluation relay. Relay “CM-MSS” is recommended for this. The threshold is preset.
Connection values: max. 250 V(AC), 2.5 A, $\cos \varphi = 1$
- Connect the PTC sensor via an evaluation relay. Relay “CM-MSS” is recommended for this. The threshold is preset.
- Connect the external pencil electrode via an Ex-rated evaluation relay! Relay “XR-4...” is recommended for this.
The threshold is 30 kOhm.
- The connection must be made using an intrinsically safe circuit!

13.1.4.3 Sealing chamber monitoring (external electrode)

13.1.5 Commissioning



DANGER

Risk of explosion when using non Ex-rated pumps!

Pumps without Ex rating may not be used in potentially explosive areas! There is a risk of fatal injury due to explosion! Only use pumps which have the appropriate Ex labelling on the rating plate within potentially explosive areas.



DANGER

Risk of explosion due to flying sparks in the hydraulics!

During operation the hydraulics must be flooded (completely filled with the fluid). If the volume flow is interrupted or the hydraulics emerges, air cushions can form in the hydraulics. If this happens, there is a risk of explosion, e.g. flying sparks due to static charge! Dry-running protection must ensure that the pump is deactivated at the appropriate level.



DANGER

There is a risk of explosion if dry-running protection is connected incorrectly!

If the pump is operated within an explosive atmosphere, the dry-running protection must have a separate signal transmitter (redundant protection of the level control). Pump deactivation must be performed with a manual reactivation lock!

- The operator is responsible for defining the potentially explosive area.
- Only pumps with corresponding Ex rating may be used within a potentially explosive area.
- Pumps with Ex rating must be labelled on the rating plate.
- Do not exceed the **maximum fluid temperature!**
- Dry running of the pump must be prevented! Ensure on-site (dry-running protection) that emerging of the hydraulics is prevented.
According to DIN EN 50495, a safety device with SIL level 1 and hardware fault tolerance 0 must be provided for category 2.
- Carry out maintenance tasks according to the regulations.
- Only carry out maintenance tasks mentioned in these installation and operating instructions.
- The spark-proof gaps may **only** be repaired according to the manufacturer’s design specifications. It is **not** permitted to carry out repairs according to the values in tables 1 and 2 of DIN EN 60079-1.

13.1.6 Maintenance and repair

- Only use screw plugs as stipulated by the manufacturer, that at least correspond to a strength class of 600 N/mm² (38.85 long tons-force/inch²).

13.1.6.1 Repair of housing coating

The paint layer can become electrostatically charged in case of thicker coats. **DANGER! Risk of explosion! In explosive atmospheres, a discharge can cause an explosion!**

If the housing coating has to be repaired, the maximum coat thickness is 2 mm (0.08 in)!

13.1.6.2 Changing the mechanical seal

Changing the seal on the fluid and motor side is strictly prohibited!

13.1.6.3 Changing the power supply cable

Changing the power supply cable is strictly prohibited!







wilo



Local contact at
www.wilo.com/contact

Pioneering for You

WILO SE
Wilopark 1
44263 Dortmund
Germany
T +49 (0)231 4102-0
T +49 (0)231 4102-7363
wilo@wilo.com
www.wilo.com